



StationMaster - 6

Train Controller

This manual contains detailed hookup and programming instructions for the StationMaster-6 train controller available in a 4 AMP or 10AMP configuration. The StationMaster-6 can perform station stops and reversing operations. It can perform all the functions of the **StationMaster-5 XL Full Featured** and also contains more advanced hardware and software features described online at StationMaster.net.

The StationMaster-6 can control DC trains or DCC trains set to linear mode.

Before we Start- Please do not attach power wires (from your power pack or transformer) to any other terminals except the designated input pins 1 and 2. Your StationMaster will be damaged if power is put on any of the sensor terminals.

ONLY ATTACH WIRES WHILE THE POWER IS OFF.

Quick-connect terminals allow easy swap-out and removal of the electronics while leaving the wires in place. The RR Concepts Magnet/Screwdriver tool is recommended for wire-up and testing of operations.

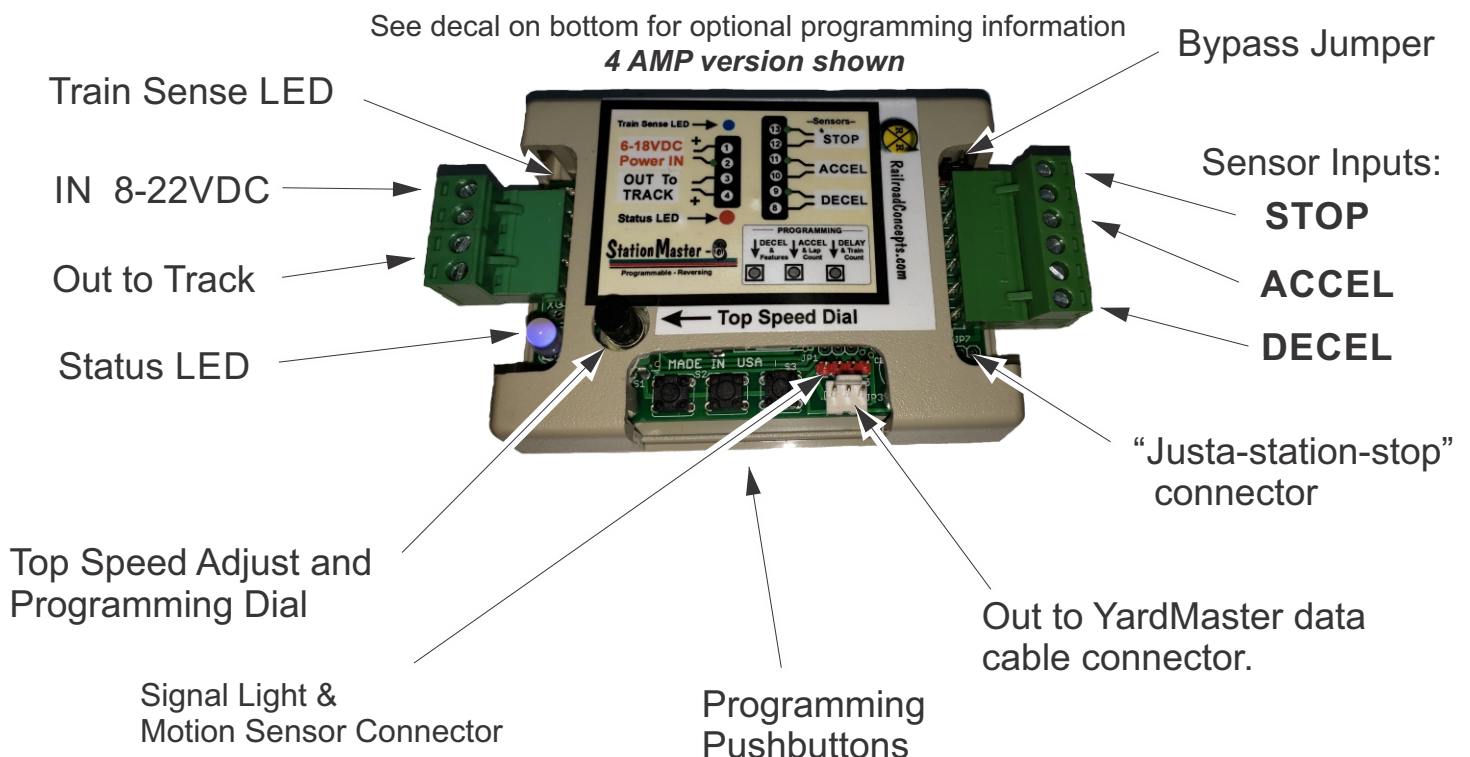

RR Concepts StationMaster - 6

Quick Hookup Instructions

How to do
Realistic Station Stops & Realistic Reversing (More details in manual)

The StationMaster works with DC (out of the box) or DCC trains set to linear mode. (N, HO, G, etc.) AC trains cannot be controlled.

StationMaster CONNECTIONS and CONTROLS

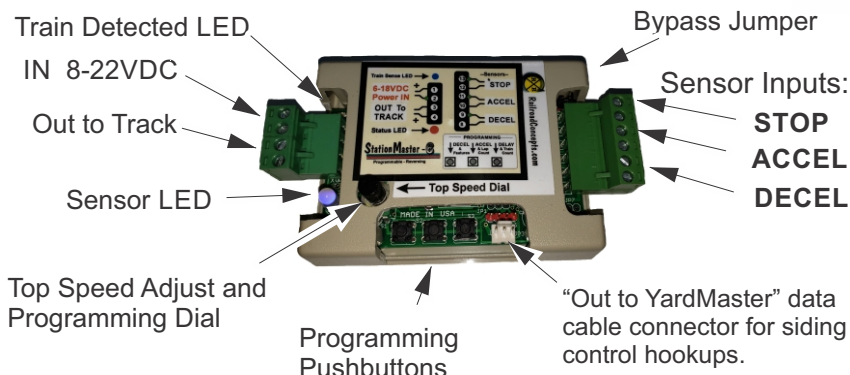

See the label on the bottom for programming and additional information.
4 AMP Version shown, Also available in 10 AMP configuration.

Station Stop Hookup

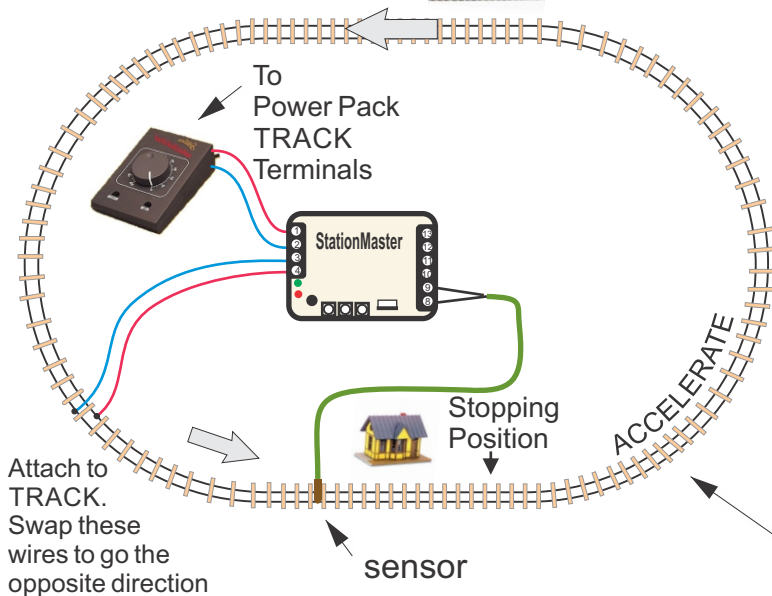

Accelerate + Decelerate Station Stop Hookup

- 1) Attach terminals 1 & 2 to the transformer.
 - 2) Attach terminals 3 & 4 to the track.
 - 3) Attach terminals 8 & 9 to a train sensor. (No polarity)
 - 4) Mount a magnet on an engine or car.
- Set the transformer to the desired top speed. That's it!

See the online manual for optional additional features:

- * Change acceleration rate,
- * Change deceleration rate,
- * Add additional station stops,
- * Do multiple laps before stopping,
- * Run 2 trains on the same track.
- * Change station stop pause duration, (Default 10 seconds)
- * Perform "Self-Adjusting" deceleration. (Requires STOP sensor to stop at an exact location)

Un-modified track!
No diodes, no breaks, no additional track connections.

Reversing Hookup



Un-modified trains.
No sensors, no magnets.
It just works!

Accelerate + Decelerate Reversing Hookup

- 1) Attach terminals 1 & 2 to the transformer.
- 2) Attach terminals 3 & 4 to the track.
- 3) Program the StationMaster for "Reversing Mode" (see below for programming)

See the online manual for additional in-between stops, self adjusting exact stopping using STOP sensors, delay times, etc,

One time programming for No Sensor Reversing mode*:

1. Turn the top speed dial fully counter-clockwise.
2. Simultaneously press buttons 1 and 2.
3. Turn the top speed dial fully clockwise.
4. When train starts to run, press button #3 about 3 feet from the end. Repeat for both directions.
5. Turn dial to desired creep speed into the ends.

Go to StationMaster.net (bottom of page) and download the 25 page user manual for more info.
 Visit RailroadConcepts.com for more fun, advanced hookups, and ordering parts.



SCAN FOR INFO

Bypass and Manual Reverse Operation

Sometimes automatic control is not desired so the StationMaster-6 contains a bypass feature.

The SM-6 is shipped with a jumper installed on a 2 pin header, however a bypass switch could easily be installed with a cable that attaches to the header. When the contacts are "open" the SM will be bypassed to allow manual control. When "closed" the SM will be operational.

The SM-6 also allows manual reverse operations. When the input voltage is reverse polarity (train transformer is backing up train) the StationMaster will disengage and allow manual control. **This means that trains can run under manual control when the direction switch on the transformer is "reversed", or the contacts on the header are "open". This will allow you to back up trains if needed.**

External Relay / Signal Light Control

The StationMaster-6 can control external devices when an Auxiliary relay is attached.

The default setting is for a station stop signal light.

When *decelerating*, *creeping*, or *stopped*, the relay will be ON; for all other cases the relay will be OFF. When a signal light is attached to the relay it could show RED when entering at the station, and GREEN when leaving.

This relay can also be configured to turn the relay ON or OFF based on the train direction, or momentarily switch when starting an acceleration or deceleration. This could be used for station sound affects, etc. See the programming mode page for details.

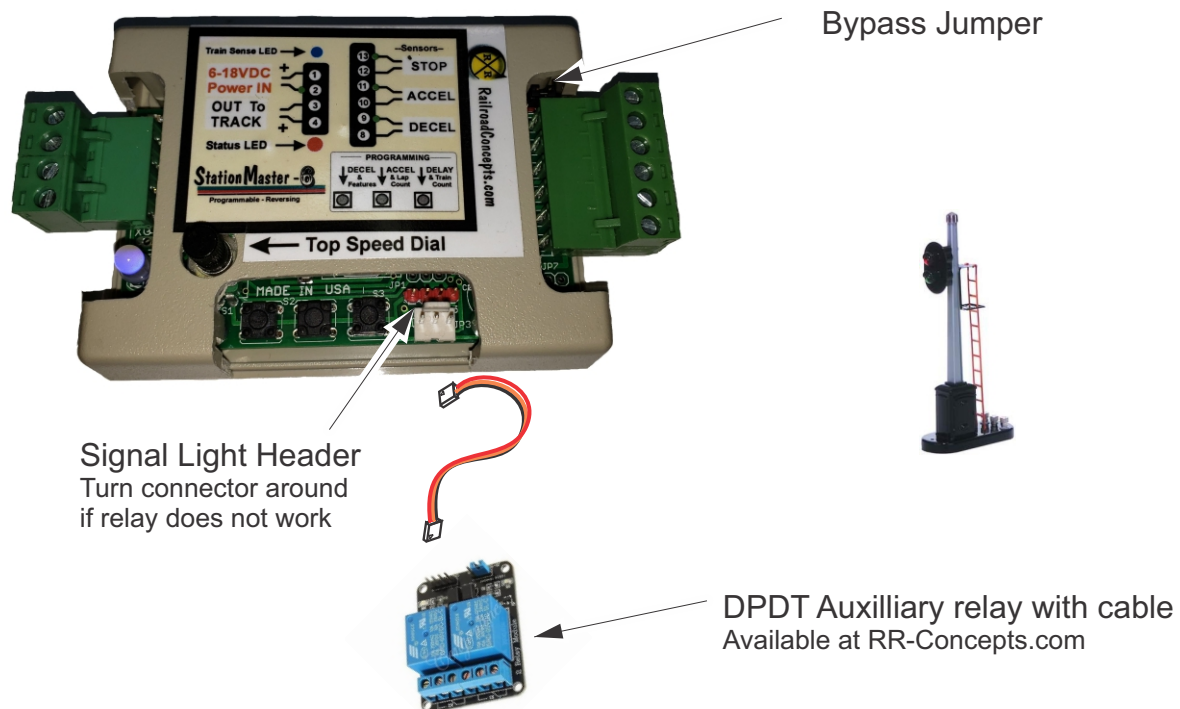

StationMaster Basic Hookup Description

The StationMaster is designed to be installed between the train transformer, and the track.

Attach terminals 1 & 2 to your transformer's DC output (Sometimes labeled as TRACK) **or** to a 12-22 volt power source. If using a train transformer set the throttle position to the desired top speed of the train. If the StationMaster does not "light up", then the input voltage is reversed OR the bypass jumper is not in place. The SM-6 contains a DC to DC converter so much higher input voltages are possible.

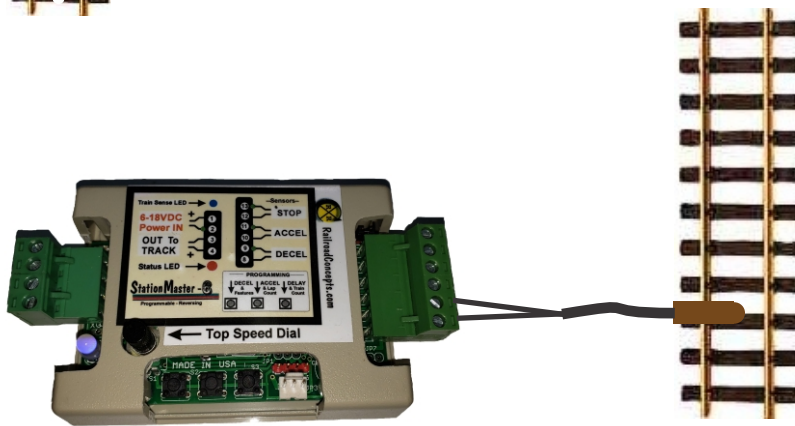
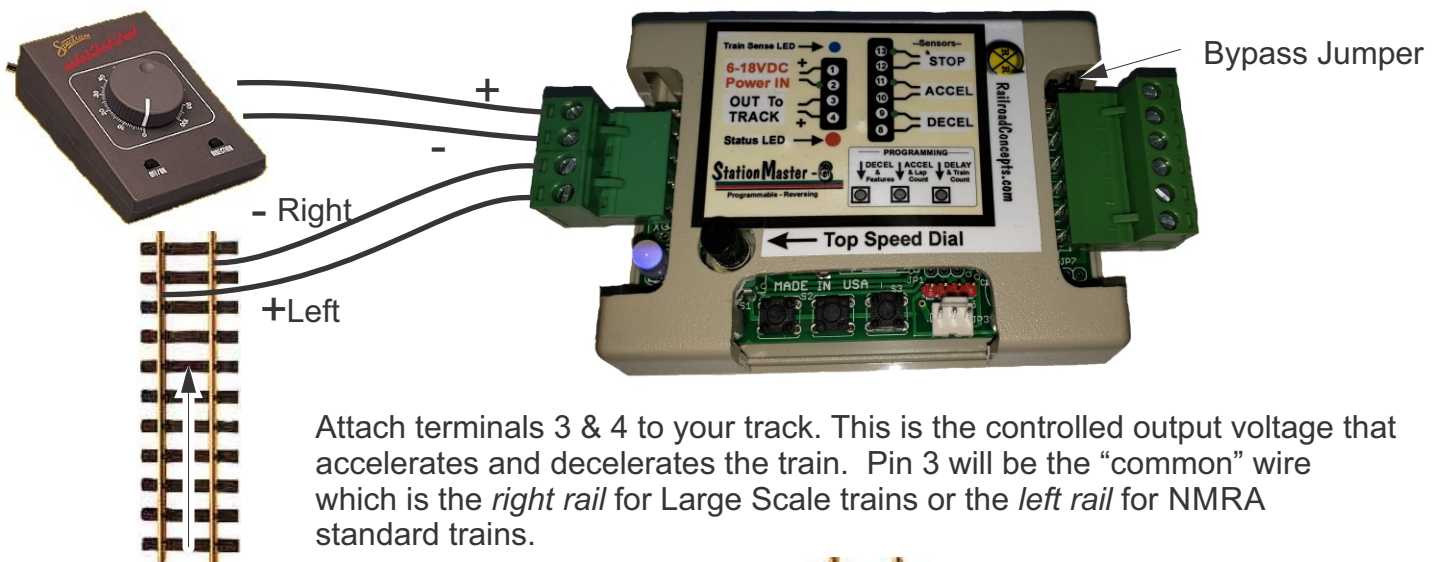

DECEL Sensor

Terminals 8 & 9 are the **start deceleration** sensor input. When these terminals are closed (sensor detects a magnet) the StationMaster will begin a decelerate, pause, and then accelerate sequence. The LED will turn WHITE for as long as this sensor is detected. By placing multiple sensors wired in parallel, the StationMaster can stop at multiple stations on your railroad.



Pressing button #1 will simulate the DECEL sensor operation.

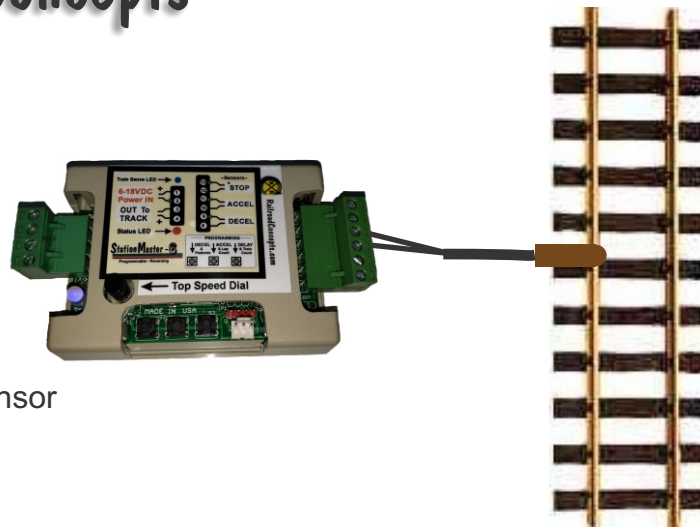

ACCEL Sensor

Terminals 10 and 11 are the optional **Start Acceleration** sensor inputs.

When these terminals are shorted (sensor detects a magnet) the train will start to accelerate.

This sensor is **not** necessary unless using “Block Control” or the **time delay** is set for maximum blinks. (See below).



Pressing button #2 will simulate the ACCEL sensor.

When programmed for “Blink1: Simple reversing mode” this sensor will perform an in-between station stop and the ACCEL function will not be operational.

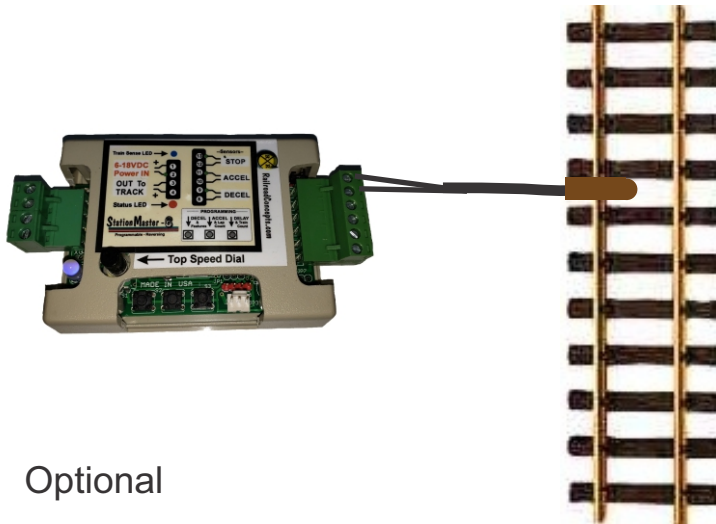

Optional

STOP Sensor

Terminals 12 and 13 are the optional STOP sensor inputs.

When the train is decelerating and these terminals are shorted (sensor detects a magnet), the train will immediately STOP. This sensor is not necessary unless using the “Creep Stop Deceleration” mode in which case it is mandatory. **A STOP sensor will have no affect unless the train has already passed over the DECEL sensor.**



Pressing button #3 will simulate the STOP sensor.

StationMaster “Deadman Timer”

A unique feature of the StationMaster is the *DeadmanTimer*.
If a train is sensed on the track and no sensor has been detected for 10 minutes, the StationMaster will SHUT DOWN and flash both the Blue train sensed LED and the GREEN status LED.

This prevents the condition where a train is hung up on an obstruction and spinning it’s wheels, most probably grinding a divot in the rails and wearing out wheels and gears.

Each time a sensor is triggered, or the train is not sensed, the deadman 10 minute timer is reset.

The Deadman Timer will be enabled AFTER the first sensor or pushbutton is pressed after power up.

How to **use** or **bypass** the Deadman Timer Shutdown:

- * When the sensor connector is pulled and trains are running “manually”, the Deadman Shutdown will not be enabled, unless a button is pushed.
- * To run “manually” and also use the Deadman Shutdown, the DECEL sensor needs to be pulled, and either the STOP or ACCEL sensor must be run over.

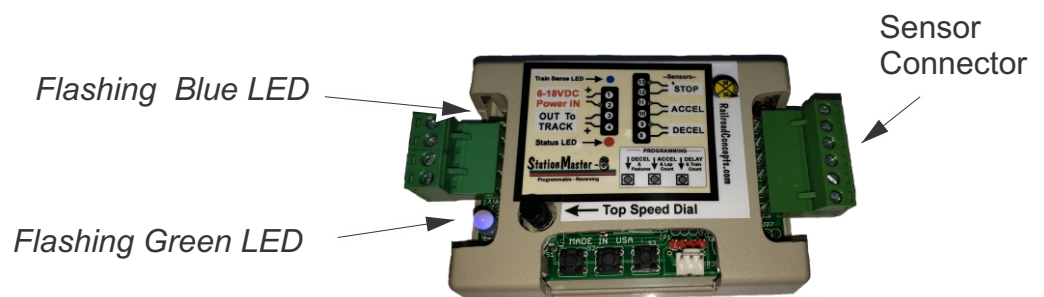

Top Speed and Programming Mode Dial



The Top Speed dial provides 3 functions:

- 1: Adjust the top "cruising" speed of the train.
- 2: Reduce the "creeping speed" when running in Diode Reverse Mode.
- 3: Enter programming mode.

Top speed adjustment

"Full speed" is clockwise. Turn this dial down as necessary to set the desired cruising speed of the train. This is only necessary when using a "fixed voltage" power supply or when a YardMaster is attached and a slow top speed is desired.

Typically, this dial is set fully clockwise and the train throttle (transformer) is used to set the speed of the train.

Diode Reverse Mode Creep Speed

When in "no-sensor Diode Reversing Mode" turn this dial down to reduce the creeping speed of the train as it enters the diode sections.

Programming Mode

To enter programming mode turn this dial fully counter-clockwise. The blue Train Detect LED will "twinkle" to indicate "programming mode".

The acceleration rate, deceleration rate and time delay can be programmed in this state. See the programming details or decal on bottom of the StationMaster for additional information.

To exit programming mode turn the dial fully clockwise.

LED indicators

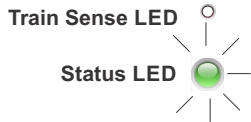
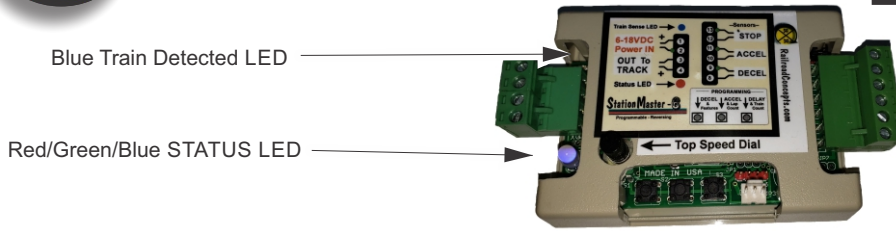

Green flashing: train is **ACCELERATING**.
Flash rate indicates the rate of acceleration.

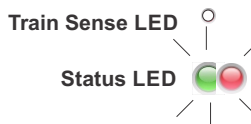

Fast alternating Red/Green Flashing: train is **CREEPING** and hunting for the STOP sensor using the creep speed.

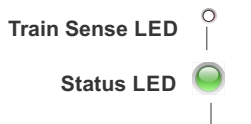

Green NOT flashing: Train is **AT TOP CRUISING SPEED**.

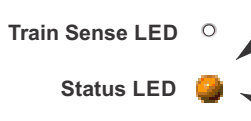

1. Orange NOT flashing, The StationMaster **will ignore next DECEL sensor** due to lap counting or block control.
 2. Orange Flashing, The StationMaster is performing a time delay.
-

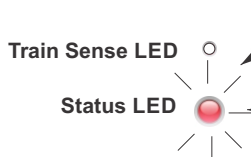

1. Quick Red flashing: Train is **DECELERATING**. Flash rate indicates the rate of deceleration.
 2. Two quick RED flashes at 1 second rate: StationMaster is **waiting for the ACCEL sensor** before accelerating. (StationMaster is programmed for infinite time delay)
-

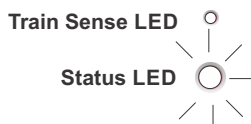

Status LED WHITE flash: **A sensor is detected**

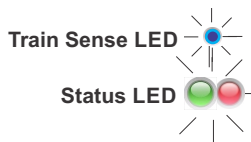

Both blinking LED's indicate a SHUTDOWN. **Red = SHORT CIRCUIT, Green = Deadman timer**. To recover: Turn the top speed dial to zero and then back to 100%, press button #1, or cycle power. If condition returns after recovery then check for a short circuit on the track or **re-program the shutdown threshold by pressing button #3 while flashing.**

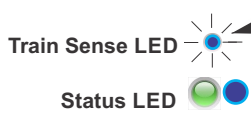

A blue Train Sense LED twinkling indicates programming mode.

No color is primary programming mode. A GREEN status LED indicates SECONDARY programming mode, and a BLUE LED indicates TERTIARY programming mode.



Programming:
Deceleration Rate

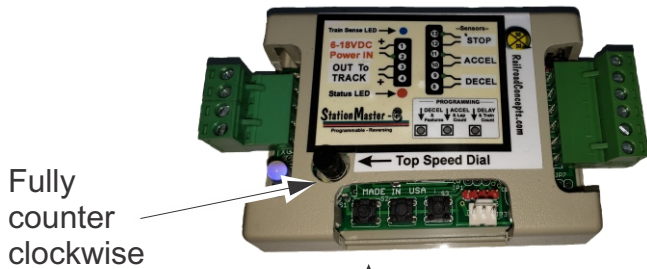

1. Make sure all three sensor inputs are open.
2. If the top speed dial is not already at zero, then turn the top speed dial to zero. (fully counter-clockwise.) The Blue “Train Detected” LED will “twinkle”
3. Push and hold programming button #1.
4. Watch the status led. Each RED blink will decelerate slower.
The fastest deceleration will be with one blink. (TRAIN Stops sooner) Release the pushbutton when the desired number of blinks have occurred. A typical number is 5. Repeat this procedure if you want a different value.

One blink corresponds to a 3 second deceleration rate. Each additional blink adds 1 second. For example, a blink count of 5 would result in a deceleration rate of 8 seconds.



When finished with all programming turn the top speed dial fully clockwise and then turn down to a desired top speed if needed.

All programming values are stored in flash memory and are retained until re-programmed.



Programming: Acceleration Rate

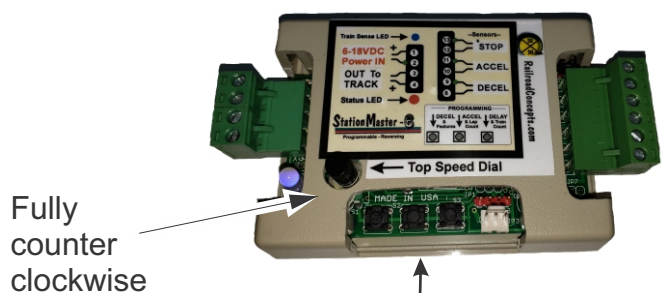

1. Make sure all three sensor inputs are open. (Red LED is off)
2. If the top speed dial is not already at zero, then turn the top speed dial to zero. (fully counter-clockwise.) BlueTrain Detected LED will “twinkle”.
3. Press and hold programming button #2..
4. Watch the status led. Each GREEN flash will accelerate slower.

The fastest acceleration will be with one blink.

Release the button when the desired number of blinks have occurred. A typical number is 5. Repeat this procedure if you want a different value. One blink corresponds to a 3 second acceleration time. Each additional blink adds 1 second. For example, a blink count of 5 would result in a acceleration rate of 8 seconds. A factory default will set to 5.



When finished with all programming, increase the top speed dial clockwise to MAX and then down to a desired top speed. All programming values are stored in flash memory and are retained until re-programmed.

A Note on Realistic Accelerations:

- * For blinks 1 thru 9 the train will accelerate linearly with the programmed value. This may be required for some block control operations where a second train is approaching and the first train needs to quickly accelerate to get out of the way, or for a trolley which accelerates quickly.
- * For blinks 10 and above the train will creep very slowly out of the station and then continue accelerating as it continues down the main line. This provides a very realistic operation as a train creeps out of a siding or station and shows off sound systems with incredible realism.
- * 10 blinks will creep for 5 seconds.
- * 11 blinks will creep for 10 seconds.
- * 12 blinks and up will creep for 15 seconds.



RR Concepts

Fully
counter
clockwise



Programming: Pause Time

1. Make sure all three sensor inputs are open. (red Led is off)
2. If the top speed dial is not already at zero, then turn the top speed dial to zero. (fully counter-clockwise.) BlueTrain Detected LED will “twinkle”.
3. Press and hold programming button #3.
4. Each ORANGE flash will increase the waiting time after a station stop.
A wait time of zero will be with one flash.
Release the button when the desired number of flashes have occurred.
Repeat this procedure if you want a different value.

The LED will turn orange when an infinite delay is set (after 13 counts).

When infinite delay is set, then the ACCEL sensor is required to start up the train after a station stop.

A fun thing to do would be to connect the ACCEL terminals to a doorbell switch. Your train would patiently wait until someone pushed the button! Motion sensors are another possible way to start the train.

When finished with all programming increase the top speed dial clockwise to maximum or to a desired top speed. All programming values are stored in flash memory and are retained until re-programmed.



The number of orange FLASHES will correspond to the following time delays:

- 1: 0 seconds, no wait.
- 2: 5 seconds
- 3: 10 seconds
- 4: 15 seconds
- 5: 20 seconds
- 6: 30 seconds
- 7: 1 minute
- 8: 2 minutes
- 9: 5 minutes
- 10: 10 minutes
- 11: 30 minutes
- 12: 60 minutes
- 13: Infinite, wait for GO sensor. This is for block control operations.



Please go to RRconcepts.com to view an informational video on how to program operating modes.

Programming: Operating Modes

HOW TO PROGRAM: (Perform a factory reset to clear everything)

1. **Enter Secondary Programming mode:** (Skip this step if already in secondary programming mode)

- * Turn the Top Speed dial fully counter-clockwise to enter programming mode (Skip this step if already in programming mode).
- * Turn the Top Speed dial slowly clockwise until the sensor LED turns green. This indicates secondary programming mode. This should be about half-way.

2. **Press and hold programming button #1** until the desired number of blinks have occurred. Each blink will set or clear a different feature. If currently ON it will turn off. If OFF it will turn ON.

When finished do not power off without first turning the dial fully clockwise.



Programmable Modes: (Any or all of these or all can be programmed independently)

- Hold button for 1 blink = Simple Reversing Mode, ignore next sensor after reversing, ACCEL sensor will perform an in-between station stop.
- Hold button for 2 blinks = Fire YardMaster before acceleration. (Default ON in reversing mode)
- Hold button for 3 blinks = Fire YardMaster after train has stopped. (Set after factory reset)
- Hold button for 4 blinks = Use automatic train detection to start deceleration. (No-sensor station stops)
- Hold button for 5 blinks = Reverse direction before every acceleration. Never ignore sensors.
- Hold button for 6 blinks = Only fire YardMaster in forward direction. (For reversing operations with a siding on one end)
- Hold button for 7 blinks = Shut off current sensor. This could cause damage to the StationMaster unless the transformer can provide short-circuit shutdown. This is sometimes necessary when running with very small transformers. (1 AMP or less)
- Hold button for 8 blinks = Turn on "creep stop". The train will decelerate then creep until reaching the STOP sensor. LEDs will flash RED/GREEN when creeping.

When the button is released the StationMaster will echo the currently programmed features (modes) by blinking the red/green LED 8 times. *For example*, if "Fire YardMaster after train has stopped" has been programmed (button pressed for 3 blinks, or after factory reset) and nothing else is programmed then the StationMaster will blink:

- blink 1 RED: Reversing mode is OFF.
- blink 2 RED: Fire YardMaster before acceleration OFF
- blink 3 GREEN: Fire YardMaster after stopping ON
- blink 4 RED: Use train sensor to start deceleration OFF
- blink 5 RED: Reverse direction before every acceleration OFF
- blink 6 RED: Only fire YardMaster in forward direction OFF
- blink 7 RED: Disable current sensor: OFF
- blink 8 RED: Creep-stop mode : OFF

Each time a feature is programmed that feature will toggle on or off. (Toggle means the feature will go OFF if currently ON, or ON if currently OFF). A factory reset will clear all values and set blink 3.

To view the currently programmed operating modes quickly press and release button #1.



Additional Information on Programming Modes. The hookup diagrams will identify which of these need to be set.

blink 1 = Simple Reversing Mode

This will allow reversing operations with a DECEL sensor placed at the ends wired in parallel. After reversing the very next DECEL sensor will be ignored. In-between station stops can be done by adding sensors in parallel to the ACCEL terminals. The train will stop at every location where a sensor is placed. the ACCEL sensor operation will not be operational.

blink 2 = .Fire YardMaster before acceleration.

If programmed for more than 1 train the YardMaster will fire to the next siding before accelerating This is used for passing sidings where a train will stop and allow a train to pass by on the other siding.

blink 3 = Fire the YardMaster after the train has stopped.

If programmed for more than 1 train the YardMaster will fire to the next siding after the train has stopped. Note that the StationMaster will automatically set this blink after a factory reset

blink 4 = Use automatic train detection to start deceleration.

When a train is sensed entering the track section the StationMaster will start a deceleration sequence.

blink 5 = Reverse direction before every acceleration

This is similar to blink 1 however the StationMaster will not ignore any sensors and the ACCEL sensor will be operational.

blink 6 = Only fire YardMaster in forward direction. (only active in reversing mode)

This will allow a reversing operation with sidings on one end.

blink 7 = Disable current sense shutdown.

If a double RED blinking shutdown condition occurs too often then the power supply may be too small to provide sufficient current and is not reliably sensed by the StationMaster. The shutdown can be disabled however damage could occur if the transformer does not have short-circuit protection.

blink 8 = Turn on "CREEP STOP" mode.

The train will decelerate using the programmed deceleration rate, then creep until reaching the STOP sensor. If the STOP sensor is not reached within 25 seconds then the creep speed is increased.

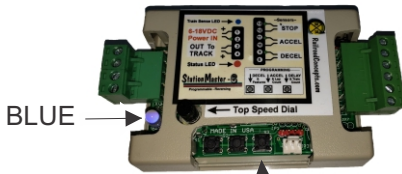

Please go to RRconcepts.com to view an informational video on how to program operating modes.

Programming: Aux Relay Control

The external auxiliary relay can be programmed to behave in four different manners. These include:

- * **Station Stop mode where the relay will turn on while entering the station and stopped.**
- * **Direction mode where the relay will turn on or off depending on the train direction.**
- * **Trigger mode, where the relay will “pulse” just after stopping.**
- * **Trigger mode where the relay will “pulse” just before accelerating.**

HOW TO PROGRAM: (Perform a factory reset to clear everything if needed)

1. **Enter Tertiary Programming mode:** (Skip this step if already in tertiary programming mode)

- * Turn the Top Speed dial fully counter-clockwise to enter programming mode (Skip this step if already in programming mode). The blue Train Detected LED will “twinkle”
- * Turn the Top Speed dial slowly clockwise until the sensor LED turns Green and then **BLUE**. This indicated tertiary programming mode. (Only available on software after 09-2019)

2. **Press and hold programming button #3** until the desired number of blinks have occurred.

When finished do not power off without first turning the dial fully clockwise.

Programmable Modes:

- Hold button for 1 blink = Station Stop mode,
- Hold button for 2 blinks = Direction mode
- Hold button for 3 blinks = Pulse at stop
- Hold button for 4 blinks = Pulse at acceleration start

To view the currently programmed operating mode quickly press and release button #3.

Additional notes for usage:

- * The “pulse” modes could be used to trigger an external sound module or other device.
- * It is also possible to use this header to directly trigger another StationMaster or YardMaster without the relay. For example, just as one StationMaster stops a train it could then trigger a second StationMaster to start up. Consult RR concepts for details.
- * The motion sensor cannot be used with the relay attached.



Fully
counter
clockwise

Programming: Factory Reset

To set the StationMaster back to factory defaults perform the following:

- 1: Enter programming mode by turning the top speed dial fully counter-clockwise
2. Press and hold both button #1 AND button #3 at the same time.
- 3 Turn the top speed dial fully clockwise to exit programming mode.



Do not power off without first turning the dial fully clockwise.

The factory default settings are:

- * Acceleration rate 5 blinks
- * Deceleration rate 3 blinks.
- * Time delay 5 seconds.
- * Train count: 2 (Note: Block control will not be operation until set for 1 train)
- * Lap count: 1
- * Operating mode (features):

Blink 1 = RED, Simple Reversing: OFF.

Blink 2 = RED, Fire YardMaster before accelerating: OFF

Blink 3 = GREEN, Fire YardMaster after train has stopped: ON

Blink 4 = RED, Use train sense to start deceleration: OFF

Blink 5 = RED, Reverse before every acceleration: OFF

Blink 6 = RED, Fire YardMaster only in forward direction: OFF

Blink 7 = RED, Disable current sensor: OFF

Blink 8 = RED, Enable CREEP-STOP mode: OFF

With these settings both the *Simple Station Stop*, and the *Alternating Trains* hookups are ready to run!



Programming: MULTIPLE LAPS

1. Turn the Top Speed dial fully counter-clockwise to enter programming mode (Skip this step if already in programming mode).
2. Slowly turn the Top Speed dial clockwise until the BLUE LED turns on. This indicates secondary programming mode. (Skip this step if already in secondary programming mode)
3. Press and hold button #2.
4. Count the blinks while the button is pressed. Release the button when the appropriate number of blinks (LAPS) are set.



When finished with all programming turn the top speed dial clockwise to maximum.

All programming values are stored in flash memory and saved until re-programmed again.



Programming: Train Count

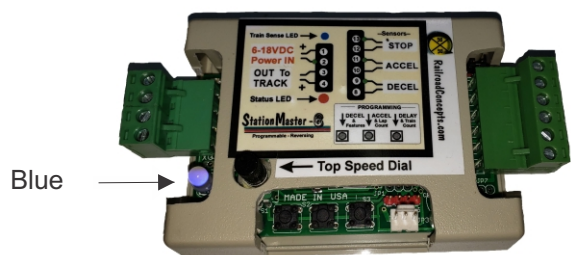

The train count is needed for 3 reasons:

1. Manage different creeping speeds for up to 5 trains.
2. Send proper signals to attached YardMasters to correctly fire turnouts.
3. Allow running in a block-control mode. (Must be set for 1 train)

For example, a 3 track siding using 2 YardMasters wired in parallel would have a train count of 3, since 3 trains will be controlled.

A factory reset will set this to 2 trains.

For an alternating siding hookup a factory reset will set this correctly.

Programming:

1. Make sure all three sensor inputs are open.
2. If not already in programming mode turn the top speed dial to zero. (fully counter-clockwise.)
3. Slowly turn the top speed dial clockwise until the sensor LED turns BLUE. This indicates secondary programming mode. (Skip this step if already in secondary programming mode)
4. Press and hold button #3.
5. Each orange flash counts the number of running trains.

Release the button when the desired number of flashes have occurred.

The number will be echoed back when the button is released..

Repeat this procedure if you want a different value.



When finished with all programming, increase the top speed dial clockwise to MAX, and then down to a desired top speed if necessary.

All programming values are stored in flash memory and saved until re-programmed again.

NOTICE: A factory reset will set the train count to 2. Block control will not be operational until set for 1 train.



“Justa Station Stop”

Justa-Station-stop performs a decelerate/Pause/Accelerate sequence *without* triggering an attached YardMaster or reversing.

When operating in an *alternating trains* hookup, additional stations stops can be done at different locations around the loop without affecting the parked train.

Add a 3 pin plug into the bottom right 3 pin header and attach the sensor to pins 1 and 3.

The Deceleration rate, Acceleration rate, and pause times are FIXED.

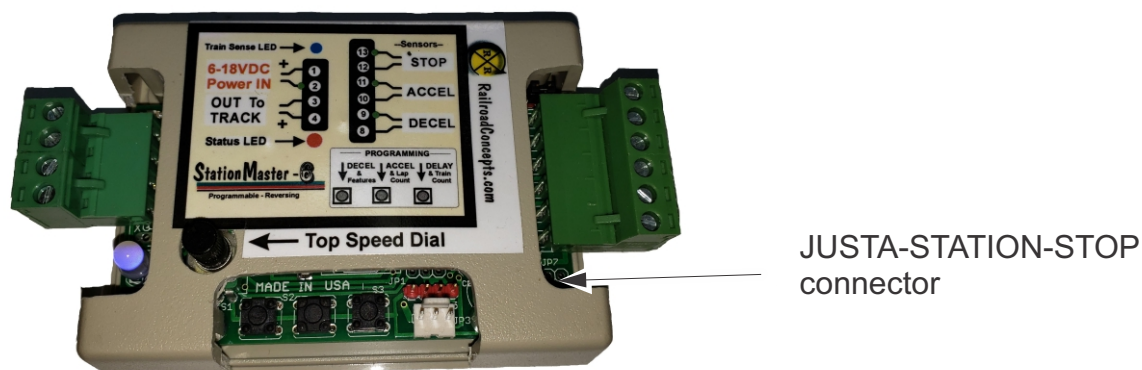

JUSTA-STATION-STOP
connector

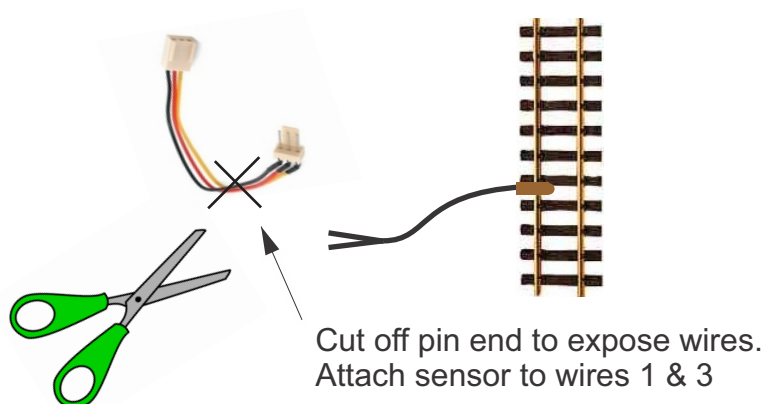



No Sensor Reversing Hookup

The StationMaster-6 includes all the features of the StationMaster/Reverser when enabled. This includes the “No-Sensor Diode Reversing Mode” where diodes are placed at the ends to stop the train. If desirable, LGB 10151 units can be use in place of diodes.

PROGRAMMING:

1. Go to programming mode. (Turn the speed dial full counter-clockwise)
 2. Press buttons #1 and #2 at the same time.
 3. Exit programming mode. (Turn the speed dial full clockwise)
- **To return to normal operations perform a factory reset** -

Here is the hookup:

- * 2 wires from the transformer to the StationMaster.
- * 2 wires from the StationMaster to the track.
- * Diodes on the ends where the engine will stop.

Reversing using Diodes

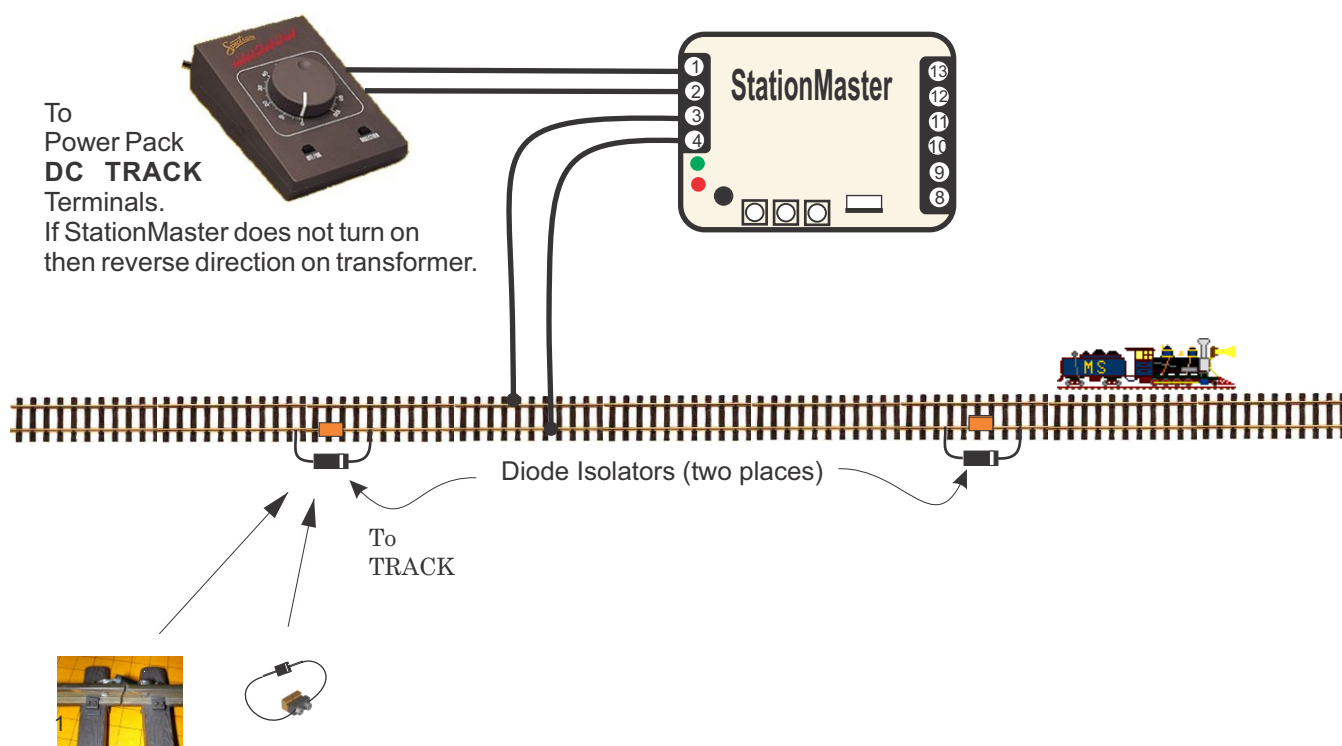

Diodes can be wired to the track using self-tapping screws or attached to an isolator. A 1 or 2 AMP diode is usually sufficient.

continued...

No-Sensor Diode Reversing Mode, Continued...

OPERATIONS:

- The Reverser has a 2 step speed profile. Speed #1 is the top speed of the train set by the transformer. Speed #2 is a “creeping” speed which allows the train to always reach the diode isolators on the ends.
- The Reverser will accelerate using the programmed acceleration rate, maintain a top speed, and then decelerate down to Speed #2 when the TIME TO DECELERATE time is reached.
- Once the deceleration has completed, Speed #2 will be maintained for the duration of the “pause time”. This provides a very realistic and smooth operation. After a reverse, the operation is repeated.

Do This Once:

- 1 **Set the transformer for the desired top speed of the train.** Turn the StationMaster top speed dial fully clockwise.
- 2 **Watch the train and press BUTTON #3 when the train reaches the TIME TO DECELERATE location.** This is typically 3 feet from the ends, but depends on the speed of the train and the programmed deceleration rate. The train will blink red and decelerate. After decelerating, the Reverser will blink RED/GREEN while the train creeps into the stops. After reversing, repeat for the other direction. Notice that the Reverser will store different TIME TO DECELERATE values for each direction since trains don't always go the same speed in forward and reverse. This will need to be done THREE times after reversing.
- 3 **To erase stored time values: Press programming buttons #1 and #2 at the same time .** Note that this is not always necessary since the TIME TO DECELERATE can be changed at any time by pressing buttons #1 (clear) or #3(SET) for the current direction. (see below,)

That's it!

Pushbutton Operations

Dial: - optional -
Turn counter-clockwise
to **creep slower**.
Note: Turning too far will enter
programming mode.

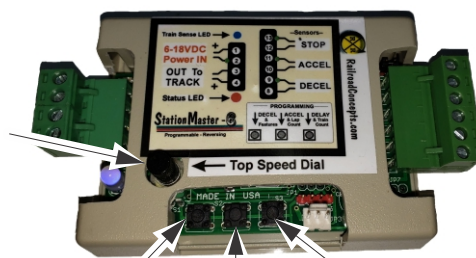

Button 1:
Reset TIME TO DECELERATE
for this direction. (start over)

Button #3:
Start deceleration NOW.

Button #2: - optional -
Terminate the time delay operation
and reverse as soon as possible.
(Convenience during programming)

Continued...



Reversing Operations - No Sensors Continued...

Notes

Most important- Always allow the trains to enter the stops on the ends before setting the TIME TO DECELERATE value (button #3). We need to record the time to start the deceleration for the full length of track.

LED Indications

This LED will:

Turn BLUE when a TIME TO DECELERATE value is **NOT** set for this direction. Button #3 **MUST** be pressed to set the deceleration time or the train will never reverse.

This LED will:

Flash GREEN when accelerating,
Flash RED when decelerating,
Slowly flash GREEN/RED during the time delay.
Blink ORANGE when an infinite time delay is running.
(When in this condition button #2 **MUST** be pressed to continue.)



Pushbutton and Dial Operations - a few more details

All recorded values are stored in flash memory and retained after a power cycle. For consistent operation day after day the transformer throttle setting should be the same. Sometimes trains will run a different speed after operating for awhile, and this is expected. To always creep into the ends set the TIME TO DECELERATE location sooner to allow more creep time.

The duration of the creep time comes from the programmed delay time. The delay time is actually “wait this long before reversing”. If a very long creep is done, then the pause at the ends will be shorter. Increase the time delay if a longer pause time at the ends is desired.

When the Reverser is running, button #3 can be pressed at any time to set the TIME TO DECELERATE. When pressed, the deceleration will start and this time is recorded.

If the deceleration is starting too soon and a different time is desired, then press BUTTON #1 to erase the stored value. This will cause the Reverser to set an infinite time delay to allow the train to creep into the stops (orange blink). Once the train enters the stops, press button #2 (terminate the time delay) to continue. Set the TIME TO DECEL again after the train reverses and comes back in this direction.

The default creep speed is relative to the transformer throttle setting. If a slower creep speed is desired, then turn the top speed dial counter-clockwise to slow the train down. Note that the creep speed will be the same for both directions. Some trains will creep faster in forward than in reverse. Note that the StationMaster requires at least 8 volts to operate.



RR Concepts

Basic Hookup Diagram for Automatic Station Stops with Deceleration/Acceleration using train sensors.

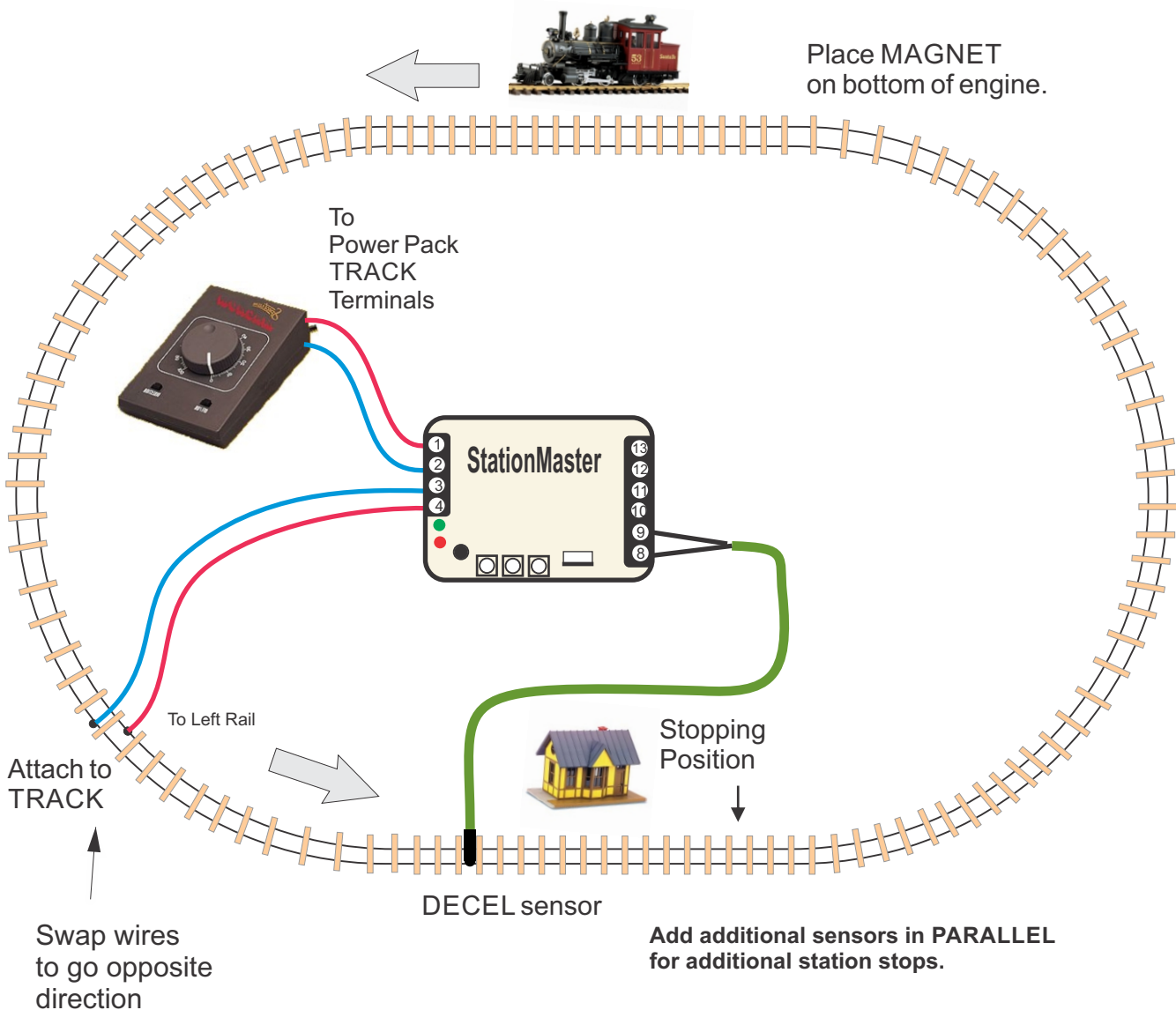

For a simple station stop, this is all you need to do!
 Factory settings will be a gradual acceleration, gradual deceleration and 10 second stop.

RR Concepts

Multiple Station Stops

Your train can stop at many stations on the loop by adding DECEL sensors in parallel.

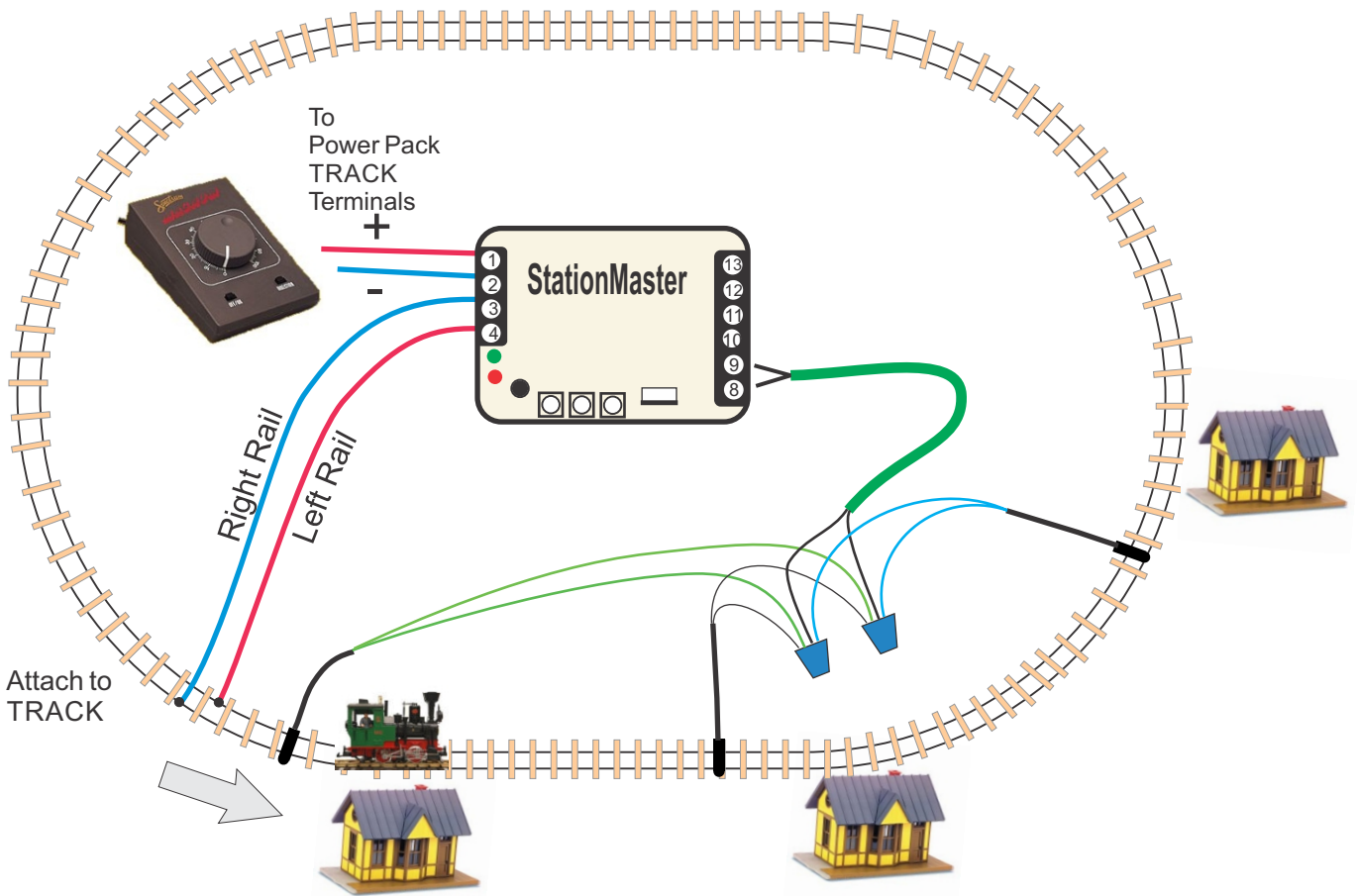

Every sensor that the train passes over will cause a decelerate/pause/accelerate sequence.



Block Control

For 1 or 2 Trains on 1 track with gradual Decelerations and Accelerations.

Can be located at a remote location on the railroad

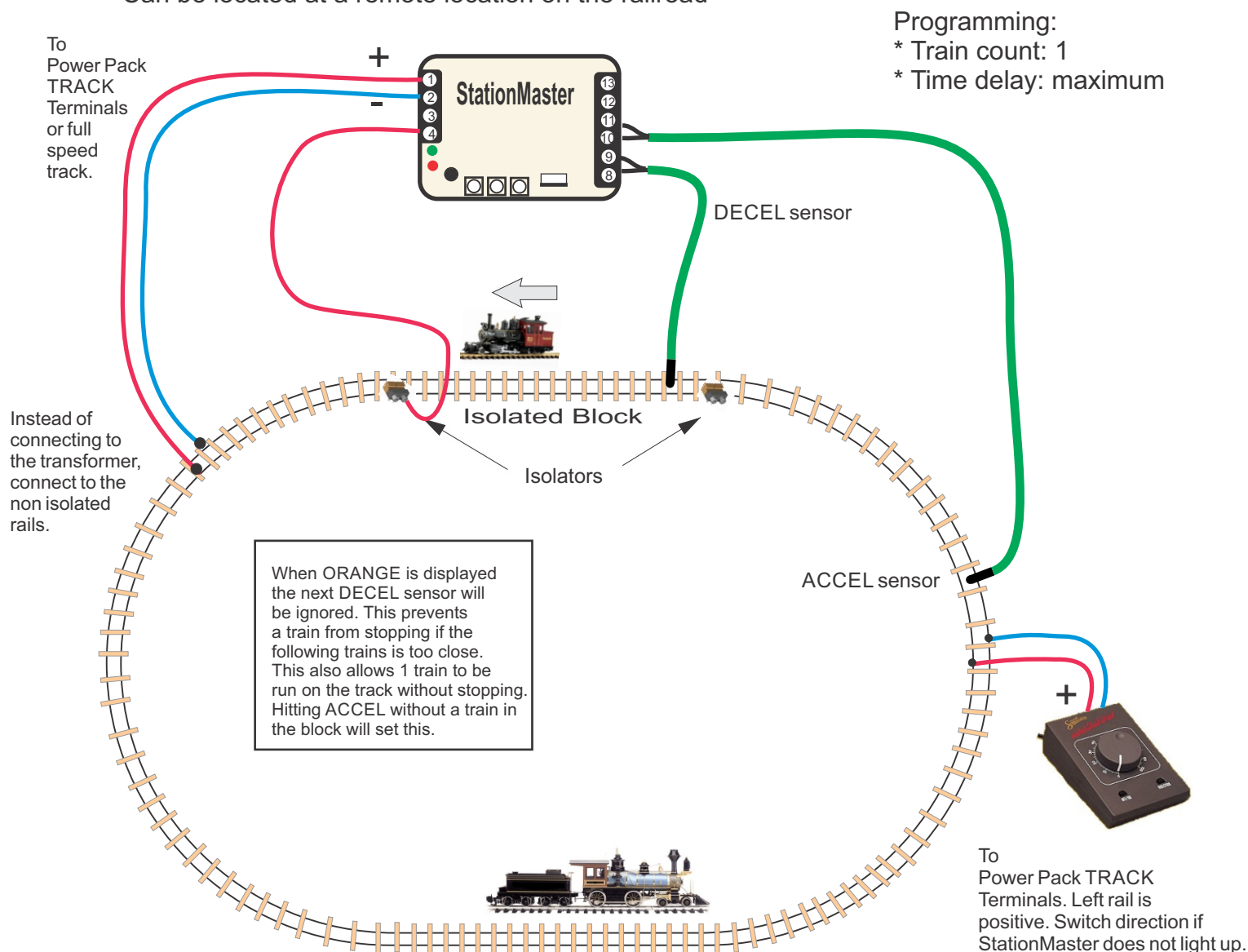

Hookup Notes:

1. Your train may not stop if the second train is too close. (ACCEL is hit before DECEL)
2. When the train decelerates it must stop before reaching the 2nd isolator..
3. If the train is slowing or stopped, then the second train will tell it to "go" when it hits the ACCEL sensor. (Start with sensor half-way around the track. Station stop will be longer with ACCEL sensor closer.) Move the location of this sensor to fit your track.
5. Location of ACCEL sensor must allow the stopped train time to accelerate and exit before the 2nd train enters the siding.
6. This hookup can run with 1 train or 2 trains. (1 train will never stop unless ACCEL sensor is removed)
7. A longer isolated section will provide more realism for the stopped train to decelerate and accelerate.
8. Station can be located at a remote location on your railroad.

TIP:

The location of the ACCEL sensor determines how long a train will wait at the block:

- * When closer to the block the pause will be longer.
- * When farther away both trains will run for a longer amount of time.

RR Concepts

Block Control

For 1, 2, or 3 Trains on 1 track with gradual Decelerations and Accelerations using StationMasters.

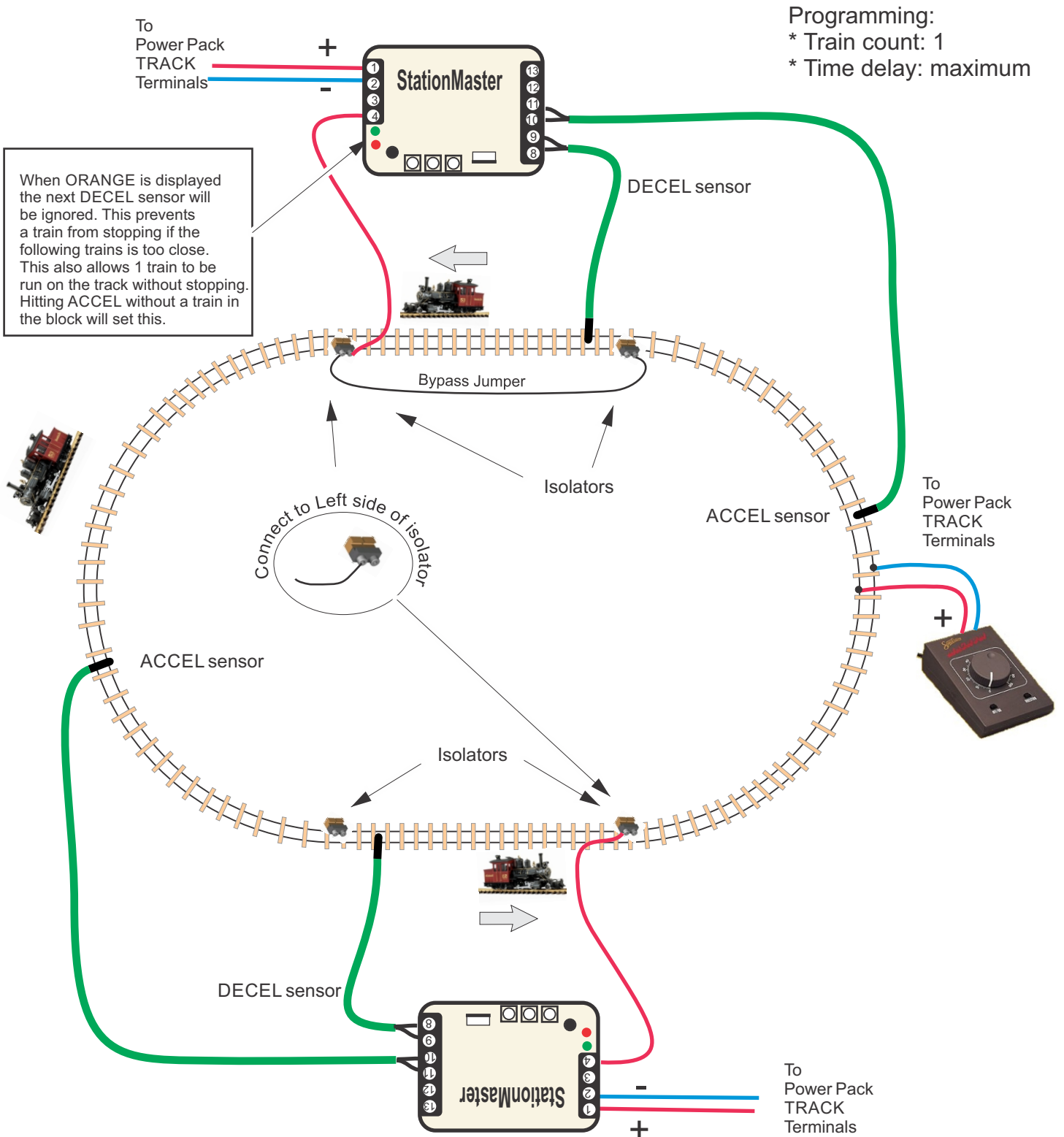



No Sensor Station Stop

Using the Automatic Train Detection feature.

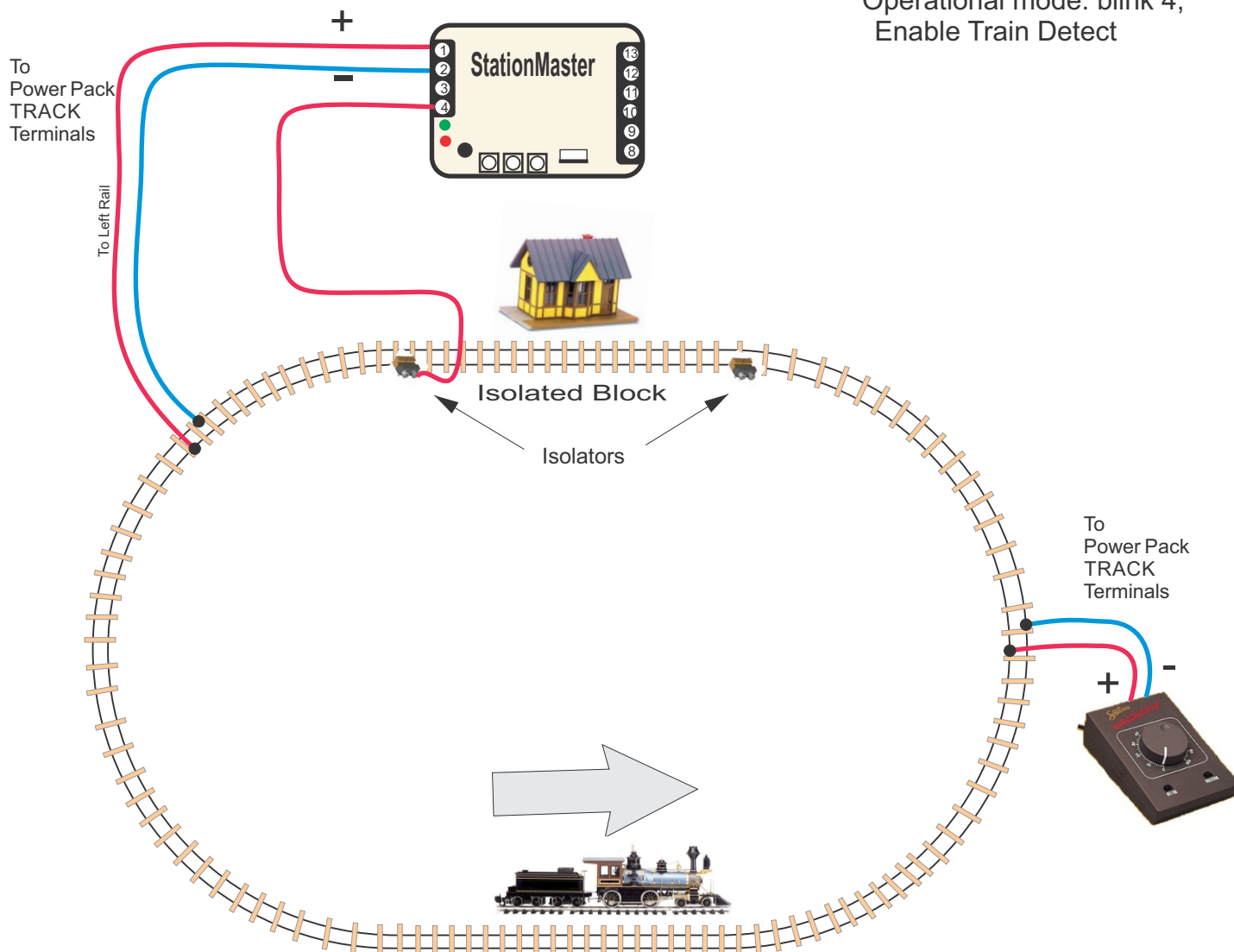

Programming:

* Operational mode: blink 4,
Enable Train Detect

Hookup Notes:

1. Isolated section must be long enough to allow the train to decelerate and accelerate.
2. Train can only go in one direction.
3. Program StationMaster for "blink 4".
4. Program time delay as desired.
5. No magnets or sensors are required
6. Station stop can be located at a remote location on your railroad far from the transformer.
7. StationMaster-6 shown. A protection diode is recommended when a StationMaster-5 is used.

“Creep-Stop” Deceleration for Incredible Realism

A unique and extremely realistic feature of the StationMaster is “Creep-Stop” Deceleration. By using both a DECEL sensor and a STOP sensor the StationMaster will provide a very realistic station stop. Programming your StationMaster to use “Creep-Stop” is very easy:

1. Set bit 8 in programming mode.(Press and hold button #1 in SECONDARY Programming mode until the LED blinks rapidly)
2. Place the **DECEL** and **STOP** sensors on your track as shown. The distance between sensors should be about 2 to 6 feet, or whatever looks good to you.
3. Program the deceleration rate (if needed) to provide a realistic deceleration into the train yard before the creep starts.

That's it!

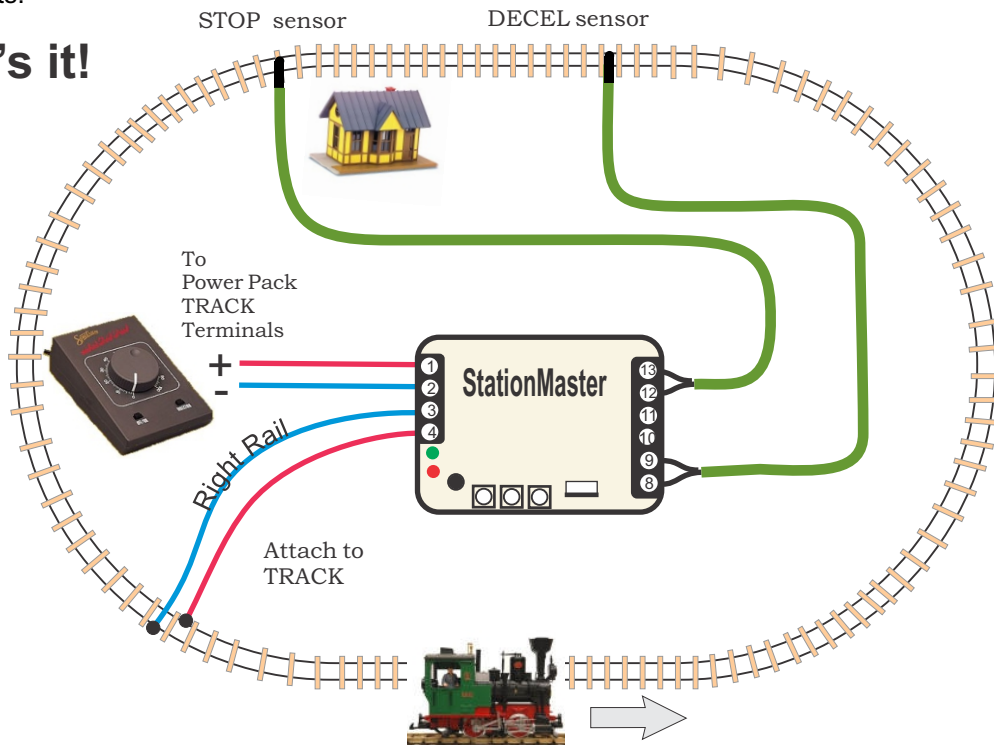

When “Creep Stop” is enabled, the train will decelerate using the programmed deceleration rate, then “creep” forward until the STOP sensor is reached. This guarantees the train will always stop on the STOP sensor using a realistic profile. The starting creep speed is relatively slow however the train must reach the STOP sensor within 25 seconds. If the train stalls, (which is expected most of the time) then the creep speed is increased for the next time. Don’t touch the train if it stalls, after a delay it will increase the speed and travel to the STOP sensor. Eventually the train will not stall. Creep speeds are stored in flash memory and retained until reset by entering programming mode.

The length of the creeping can be adjusted by either increasing or decreasing the distance between DECEL and STOP sensors, increasing or decreasing the deceleration rate, or both. Start with a 4 foot distance and see how that looks.

Up to 5 different creep speeds can be used for 5 different trains. Slow trains can run next to fast trains and each will creep perfectly, Use the “train count” to set the number of trains that will be run. A factory default will set for 2 trains which is perfect for an alternating siding setup.

Extremely Realistic Reversing Operations

When programming Mode **blink 1** is set the StationMaster will go into sensor reversing mode.

Sensors are placed near the ends to signal the StationMaster to begin the deceleration / pause / accelerate operation. Optional STOP sensors on the ends stop the train at an exact location. Sensors have no polarity. Place DECEL and STOP sensors about 2 feet apart for realistic operation. Enable Creep-Stop if desired, and set the acceleration and deceleration rates to 1 or 2 blinks for trolleys, or as desired for all other trains.

START DECELERATION

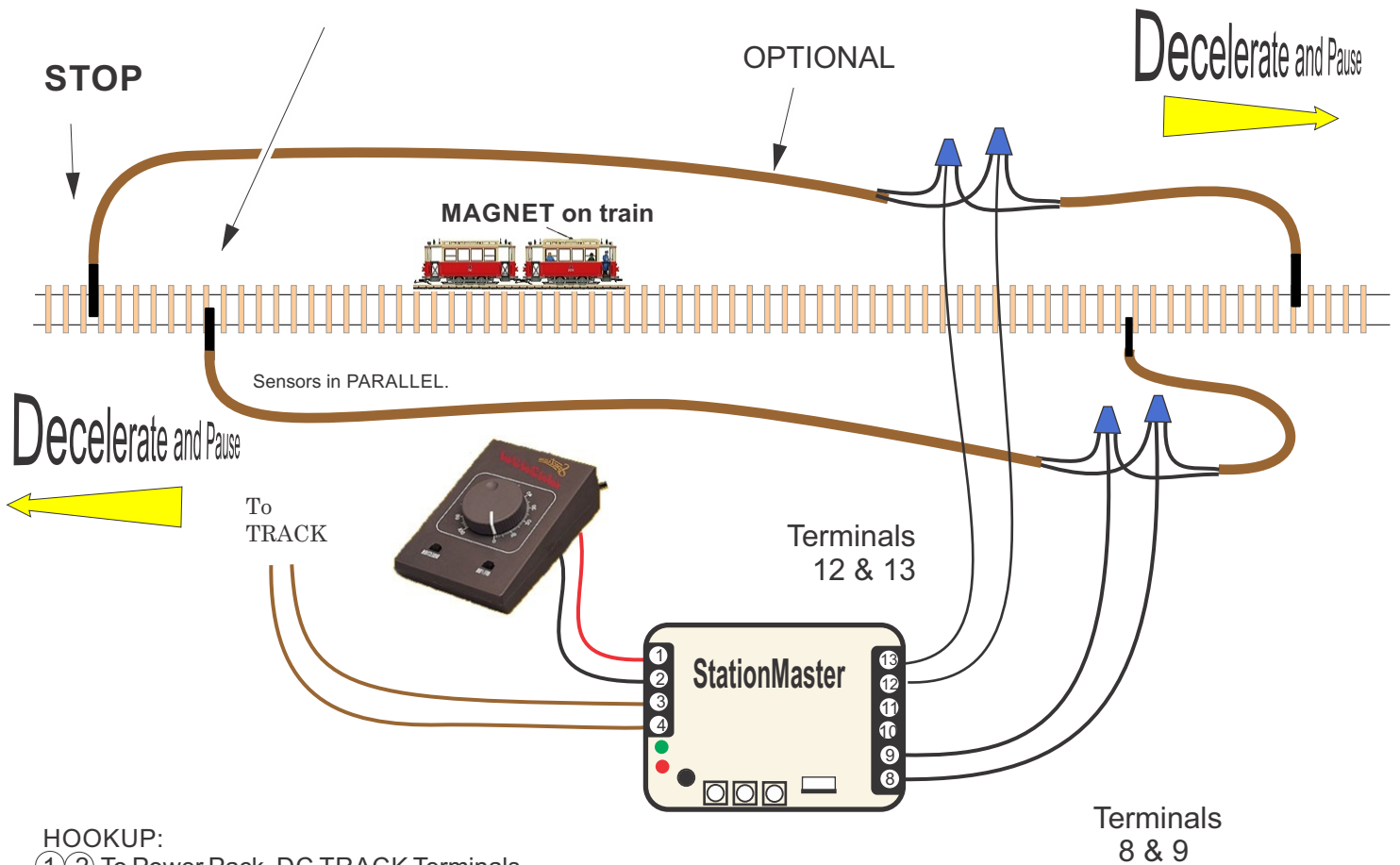

HOOKUP:

- ①② To Power Pack DC TRACK Terminals.
If StationMaster does not turn on then reverse direction on the transformer.
- ③④ To Track
- ⑧⑨ To DECEL sensors wired in parallel.
- ⑫⑬ To STOP sensors wired in parallel.



See next page for optional in-between station stops.

Extremely Realistic Reversing Operations with In-Between stops

(See the previous page for wiring the reversing operation)

When running in a back-and-forth reversing operation In-Between station stops are done by placing pairs of ACCEL sensors on the track. When the StationMaster detects an ACCEL sensor it will perform a “Justa-Station-Stop operation”. The ACCEL sensor input will not perform an acceleration operation when programmed for simple reversing mode (Blink 1)

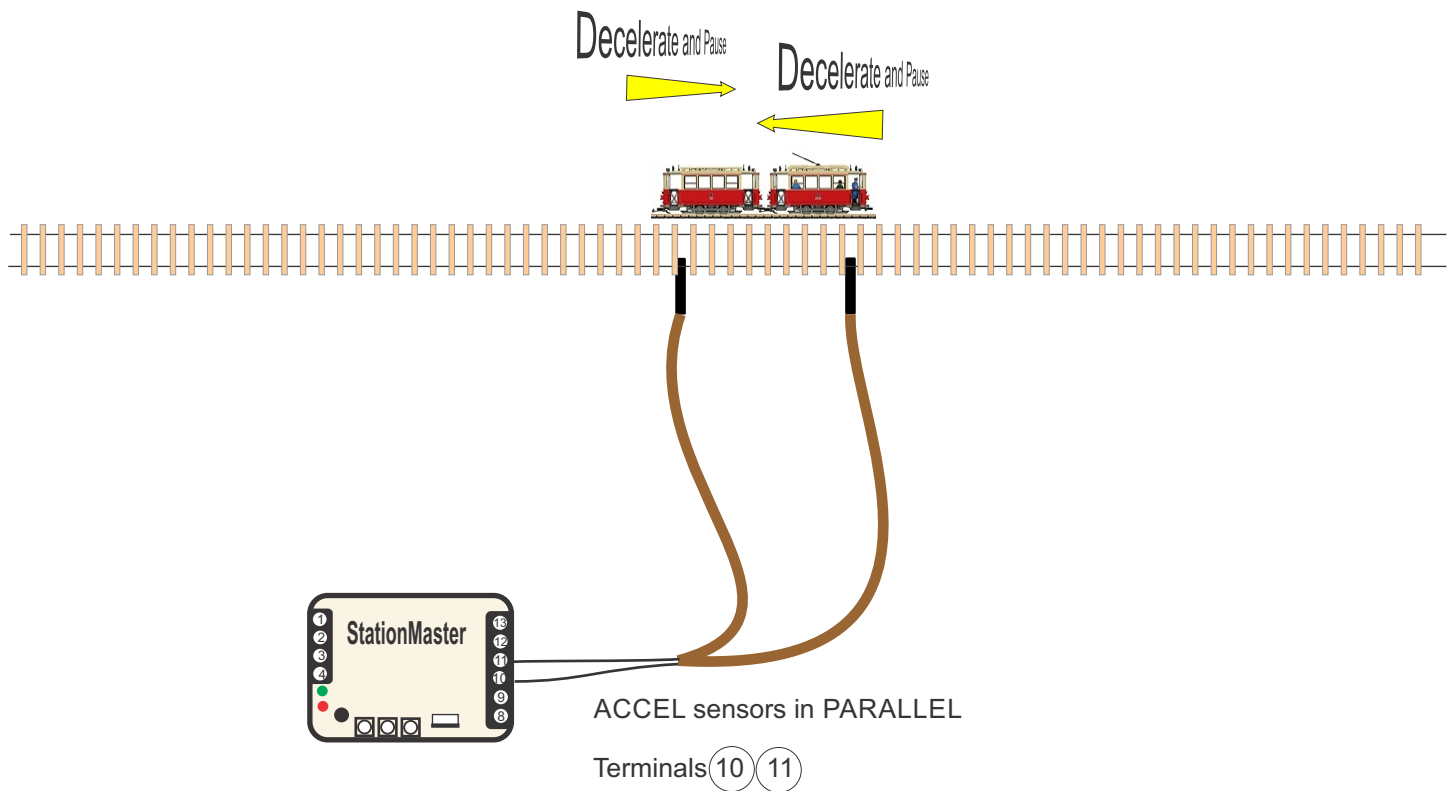

NOTES:

1. The train magnet must stop between the pair of sensors. This will allow the train to stop at the same location from either direction. When the train accelerates it will ignore the very next sensor that it passes over so it must stop before reaching the 2nd sensor. One sensor *can* be used for a single in-between stop however the train will stop at a different location for each direction. (It will decelerate and stop after passing over the sensor)
2. Sensors have no polarity.
3. Additional station stops can be done by adding additional pairs of sensors, all wired in parallel. There is no limit to the number of stops that can be done..

Alternating Trains in Opposite Directions

SPRING-RETURN TURNOUTS

TRACK CONNECTIONS

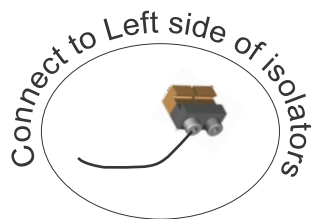
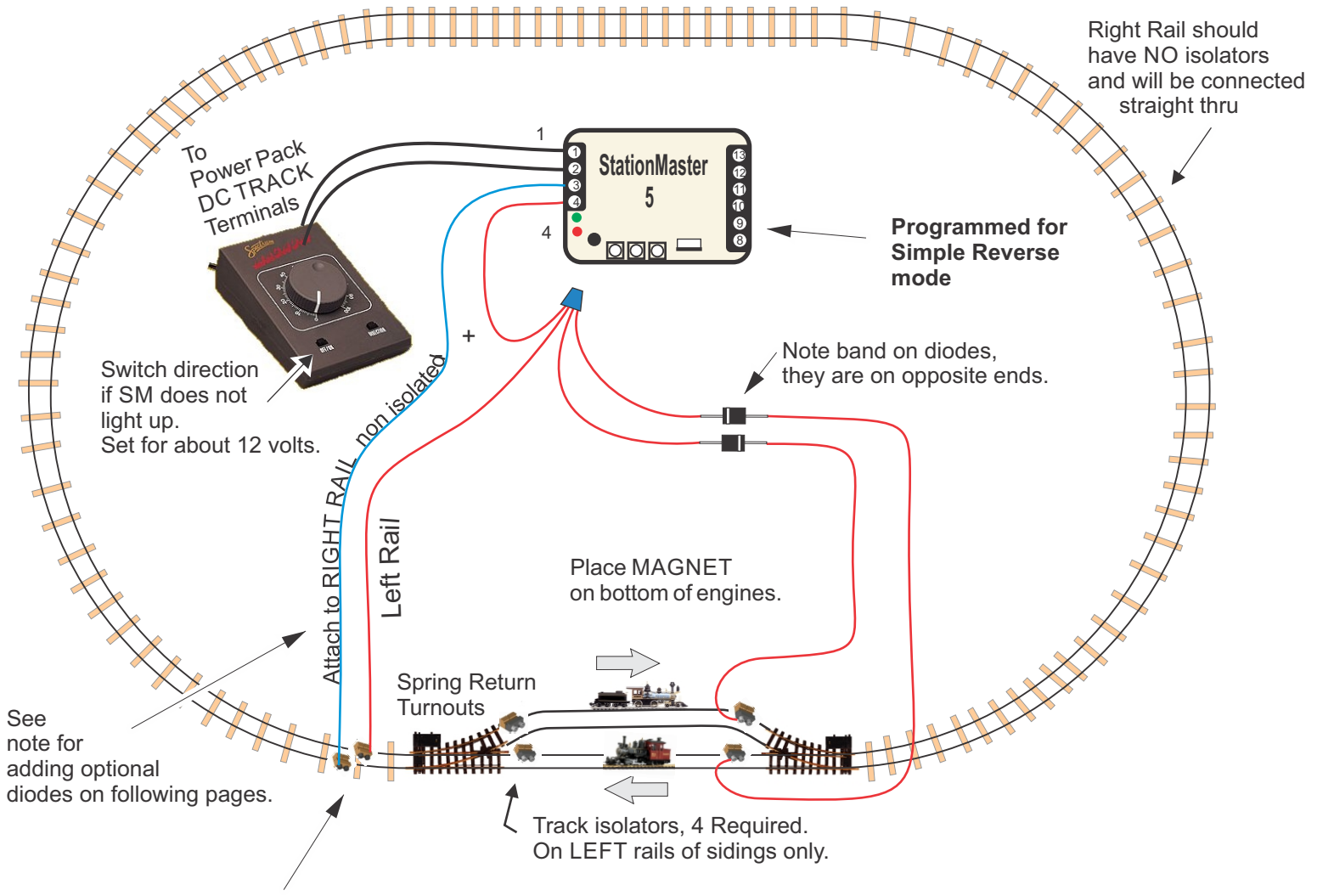

If powered turnouts are necessary use the YardMaster hookup

Alternating Trains in Opposite Directions

SPRING-RETURN TURNOUTS

SENSOR CONNECTIONS

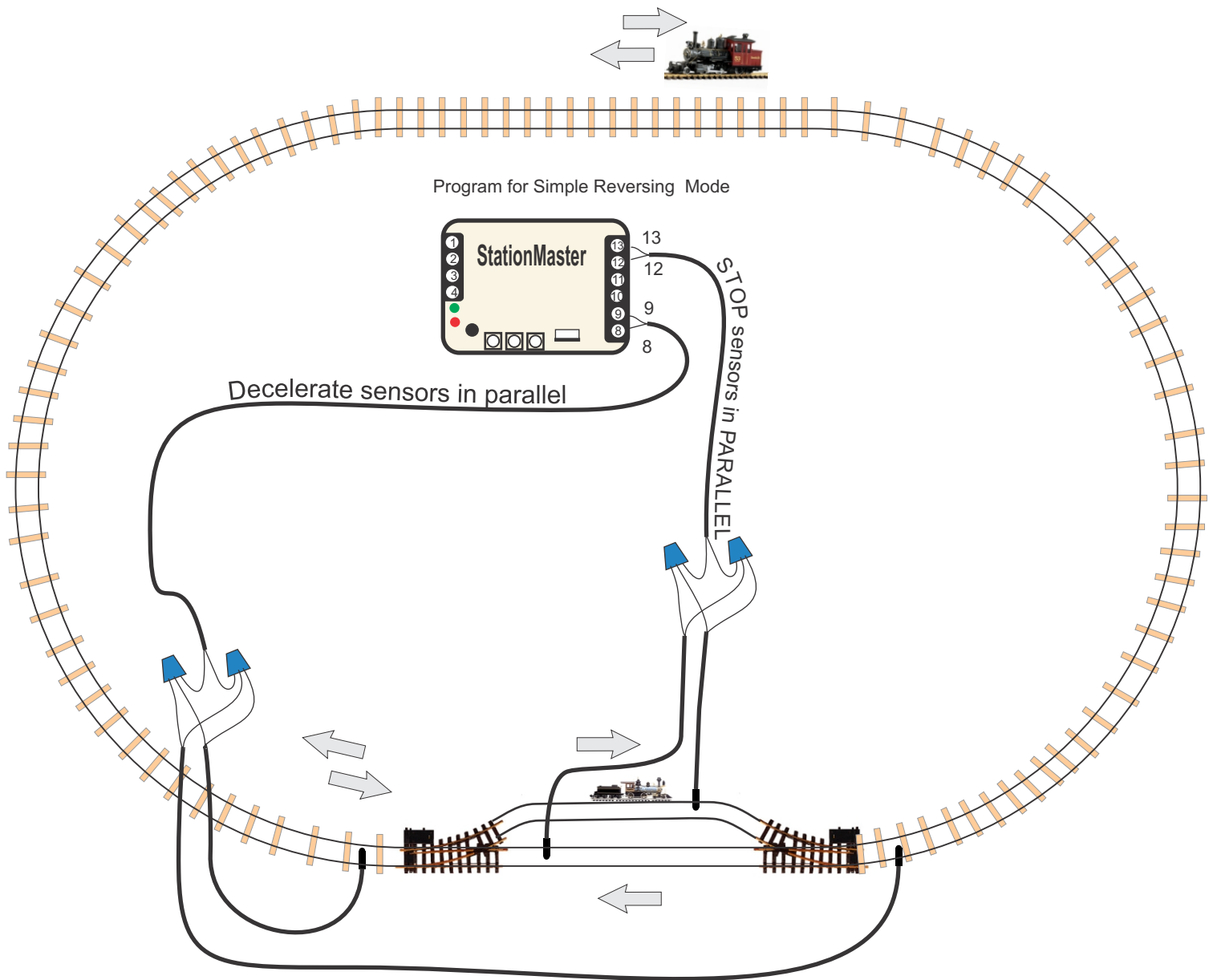

For additional station stops around the loop see "Justa-Station-Stop" in the StationMaster manual.

Alternating Trains in Opposite Directions More Details...

Parts Required:

StationMaster:	Qty 1	4 AMP or 10AMP version.
Turnouts:	Qty 2	(Both spring return)
Track Isolators:	Qty 4	
Magnets:	Qty 2	(or one per train)
Sensors:	Qty 4	
Diodes:	Qty 2	

Description

The Alternating 2 train siding will allow 2 trains to run around the layout in opposite directions. One of them will always be in the siding while the other train will be traveling. Trains will realistically decelerate and then creep into the station.

StationMaster Hookup:

Terminals 8 and 9 are the DECEL sensor inputs and attach to the DECEL sensor as shown. (No polarity) Each sensor is located where the deceleration will start. Sensors are wired in parallel.

Terminals 12 and 13 are the STOP sensor. Attach these to the STOP sensors in each siding wired in parallel as shown. (No polarity) The train will stop just past this sensor.

Terminals 1 and 2 attach to the transformer. Change the train direction on the transformer if the StationMaster does not light up.

Terminal 3 attaches to RIGHT RAIL which is common ground throughout.

Set the transformer to the desired top speed of the train.

StationMaster Programming:

- 1) Start with a factory reset for all values
- 2) Program for "Simple Reverse Mode" and "Creep Stop"
 - a) Turn top speed dial full counter-clockwise.
 - b) Turn top speed dial slowly clockwise until the GREEN LED goes on.
 - c) Press and hold button #1 for 1 blink and release.
 - d) After blinking has stopped press and hold button #1 for 8 blinks.
 - d) Turn top speed dial fully clockwise.

Optional Programming:

- * Add Multiple laps before stopping.
- * Change the Acceleration Rate.
- * Change the Pause time at the station.
- * Change the Deceleration rate so trains always go to the creep state.

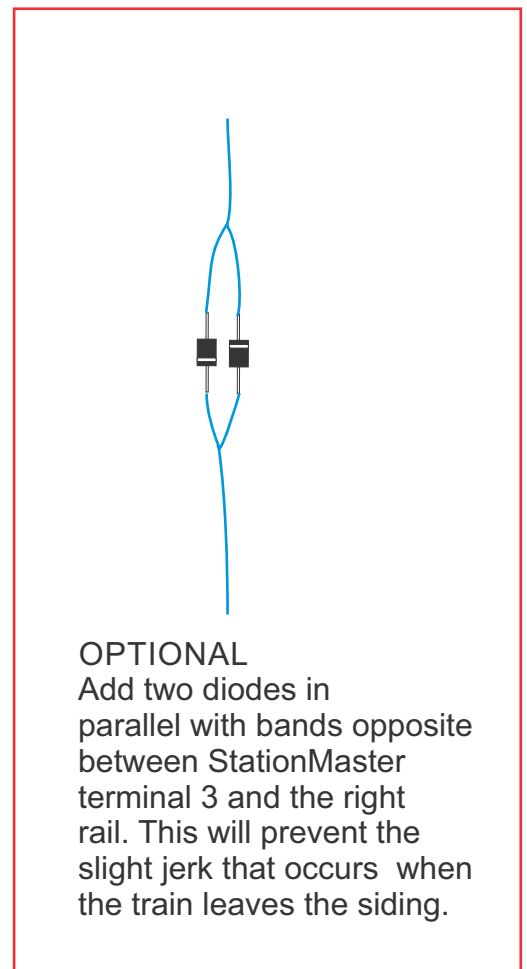

Alternating Trains

Powered Turnouts

Two trains take turns with a time delay station stop.

TRACK CONNECTIONS

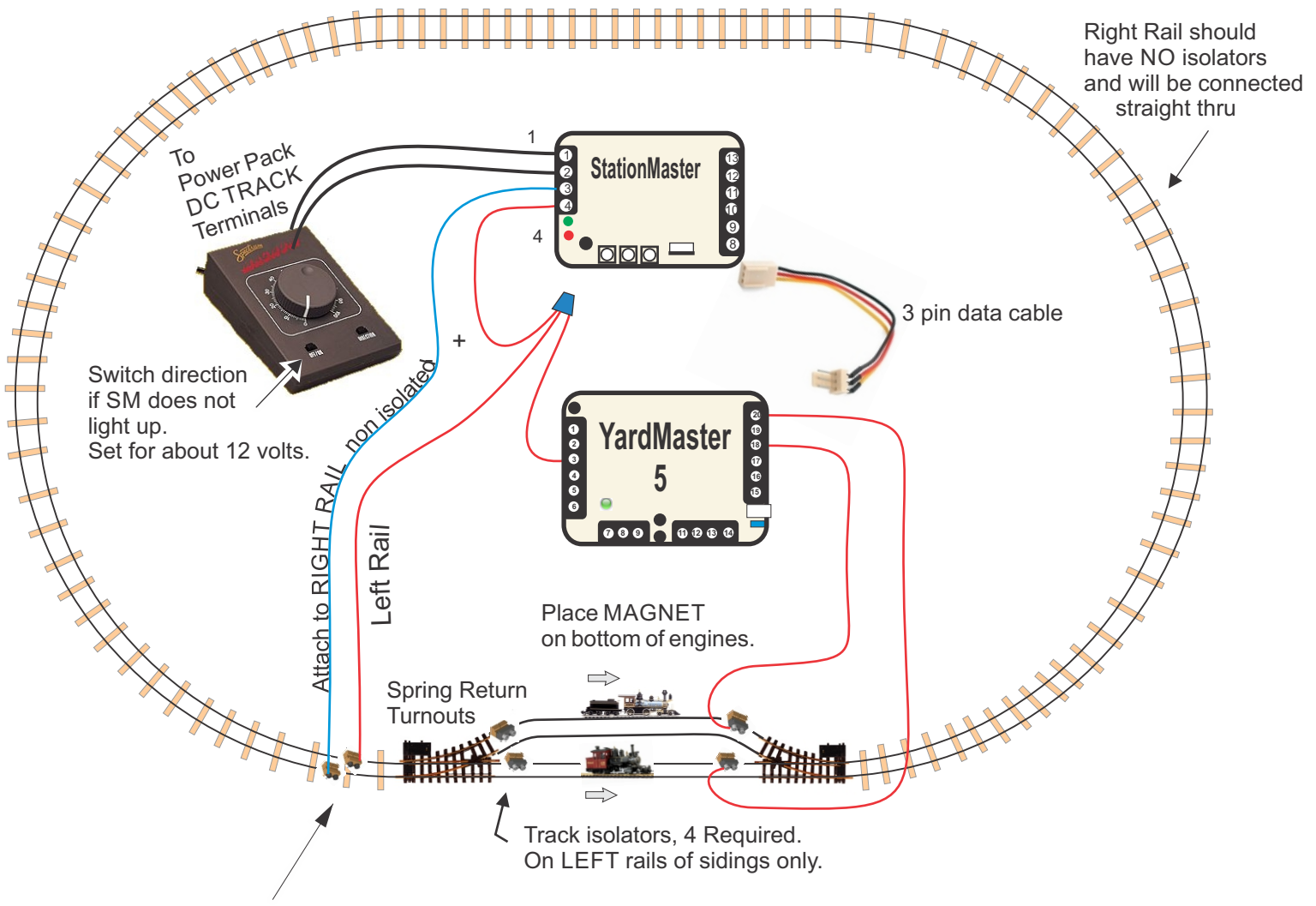

These are just connections to the rails. Non isolated. The right rail should be connected all around.

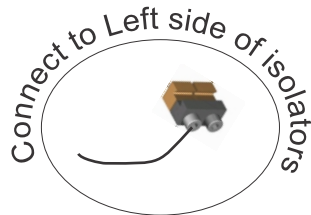

Alternating Trains Powered Turnouts

SENSOR CONNECTIONS

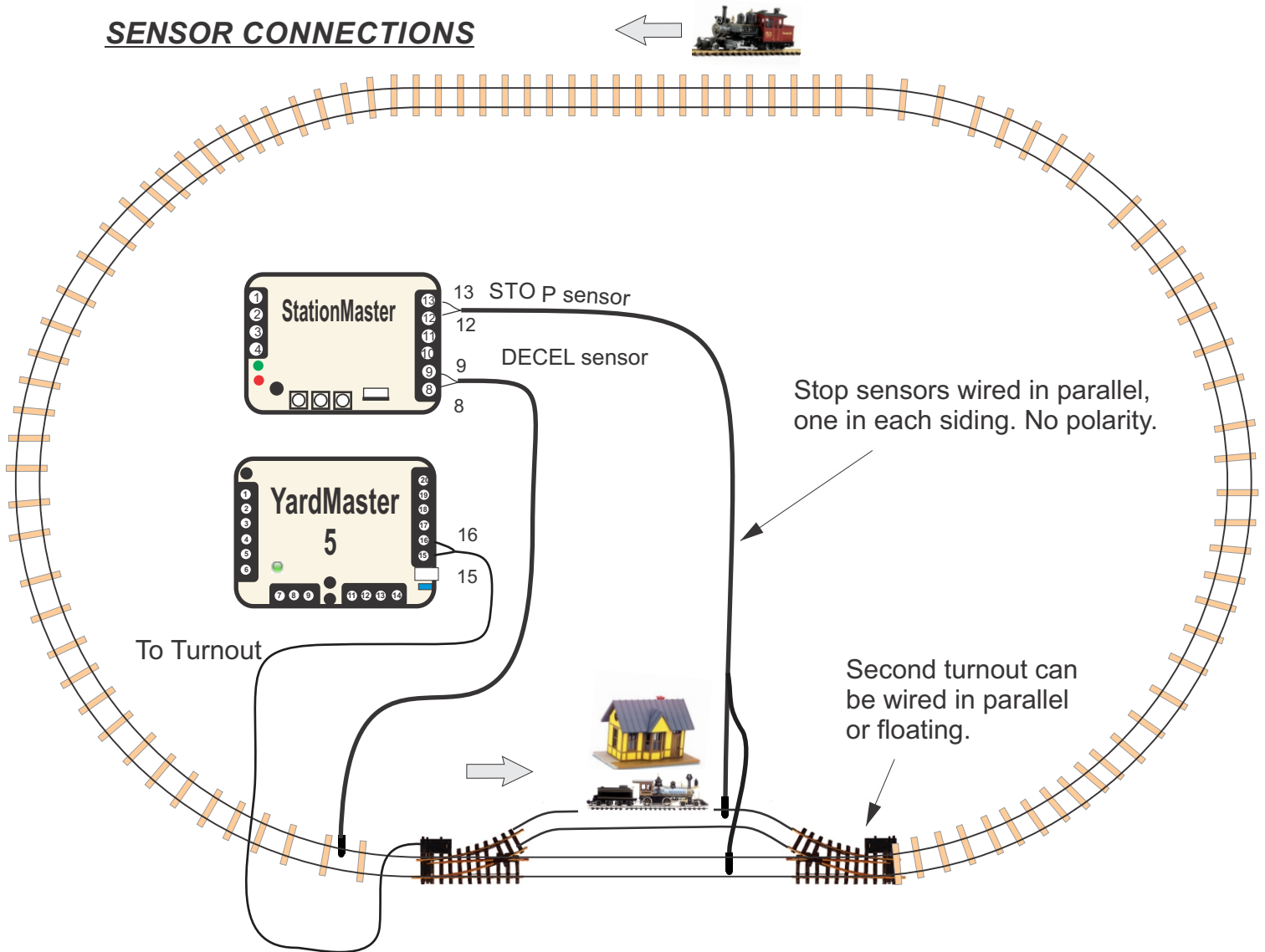

OPERATIONS

* Two trains will take turns running on the loop using an optional lap count. When the train has stopped the next train will run after the time delay.

PROGRAMMING:

1. This is the default operation after a factory reset.
2. Turn on optional "Creep Stop" for more realism so the trains creep to the STOP sensor.
3. Set an optional lap count if desired.
4. Set a longer acceleration rate if desired to creep out of the station.

Station Stop with a Siding

After a few laps on the main line, go into the siding and stop.

- == Parts List ==
 1 StationMaster-6
 1 YardMaster-5
 2 Train sensors
 1 magnet
 1 three pin data cable

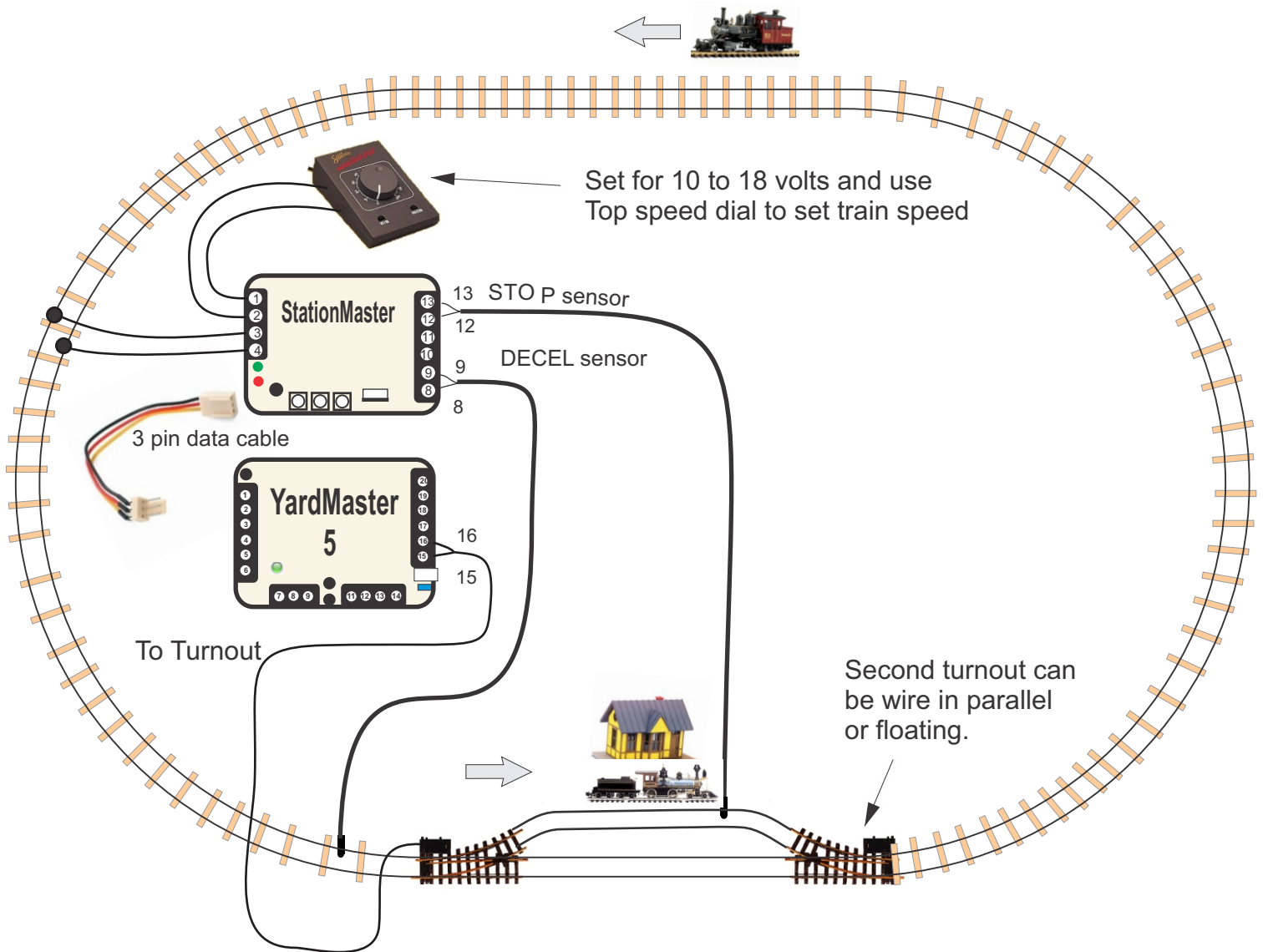

OPERATIONS

- * While counting laps, the YardMaster will fire to RED each time the DECEL sensor is ran over.
- * After the lap counting has finished, the YardMaster will fire to GREEN on the DECEL sensor and the train will stop in the siding.

PROGRAMMING:

1. Turn on blinks 2 and 3 in "features" programming. (3 is set by default after a factory reset)
2. Program a lap count greater than 1.
3. Turn on "Creep stop" in "features" programming OR set a deceleration rate such that the train reaches the STOP sensor.



Programming: Stopped Voltage

When the train is stopped, a small voltage can be put on the track to maintain lights, smoke, or sound. This feature can be set from the tertiary (third) programming mode. Notice that a setting which is too high could cause the train to creep. Choose a setting which works for your train.

HOW TO PROGRAM:

1. **Enter Tertiary Programming mode:** (Skip this step if already in tertiary programming mode)

- * Turn the Top Speed dial fully counter-clockwise to enter programming mode
The blue “Train Detected” LED will “twinkle”

- * Turn the Top Speed dial slowly clockwise until the sensor LED turns Green and then **BLUE**.
This indicates tertiary programming mode. (Only available on software after 2020)

- * At this time the currently programmed voltage will be put on the track.

2. **Press and hold button #1 to decrease the voltage, or button #2 to increase the voltage.**

Watch the train and choose a value that works.

When finished do not power off without first turning the dial fully clockwise.



Automatic Shutdown Details

The StationMaster has advanced electronics and software which will attempt to protect itself and also your trains when potentially disastrous events occur.

The first level of defense will provide a shutdown when a short circuit occurs due to a train wreck or wiring problem. Typically transformers know their current capability and will shut down when a current threshold is reached. For sensitive electronics this is sometimes too late. The only way for the StationMaster to determine a short circuit is to measure the current before that happens and record this value. When that value is reached the StationMaster will shut down and blink both BLUE LEDs.

HOW TO SET THE SHUTDOWN THRESHOLD

Since this is such an important feature, there have been many software variations, each one better than before. Your StationMaster may have either of the following :

Version 1: The shutdown threshold is set after exiting programming mode. Make sure the train transformer is set to 100% when exiting programming mode. The relays will click.

Version 2: (Current as of 11/2019) The shutdown threshold is set after a **factory reset**, and then exiting programming mode **and also by pressing button #3 when the shutdown blinking is occurring**. In both cases, make sure the transformer is set to 100%.

SMALL TRANSFORMER OVERRIDE

For small transformers it may not be possible to obtain a shutdown value, since the transformer could be operating at 100%. In this case the shutdown blinking will occur frequently and the "No Shutdown" option must be programmed. Small transformers will be less than 2AMPS or 30VA. It is unlikely the StationMaster will be stressed with a short circuit of 2 AMPS or less, and the transformer will likely shut down. Normal operations will continue after the "No shutdown" blink is set in secondary programming mode.



Motion Sensor Operations

When a motion sensor is attached to the StationMaster-6, it's possible to only run trains when motion is present. The StationMaster motion sensor operates with or without sensors as follows:

* When the DECEL sensor is detected and the train pauses at the station, the motion sensor will start up the train when motion is detected.

* If no sensors are detected then the trains will accelerate and run for as long as motion is sensed. If no motion is sensed for 2 minutes then the train will decelerate and stop until motion is sensed again.

Programming

1. Enter Tertiary Programming mode.
(Top speed down to zero, then slowly up until the LED turns BLUE.)
2. Press and hold button #3 for **5 blinks**.
3. Turn top speed dial full clockwise to exit programming mode.
4. When running with sensors, program a delay of infinite. This will cause the trains to wait until motion is sensed.



Motion Sensor Plug

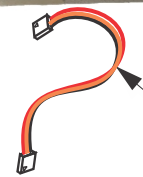

Motion Sensor Cable
Special cable with transistor.



HC-SR501
PIR Motion Sensor
(Recommended for indoor use only)

Electrical Details

For reference only

The locations of the common grounds could be useful for some wiring harnesses.

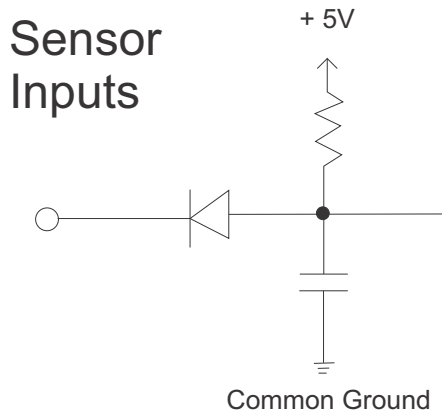
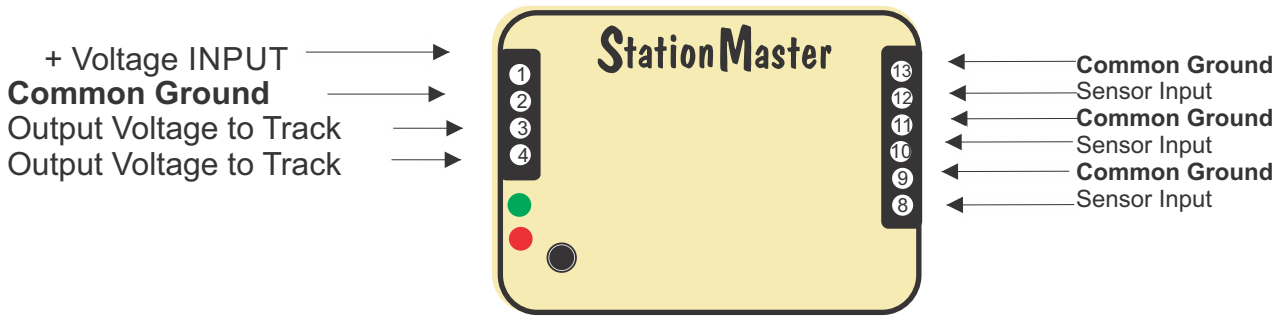

Sensor Placements on Track

The suggested sensor placement on track is shown below with the train magnet installed in the center of the train. Best sensing is done with the magnet passing over the tip of the sensor.

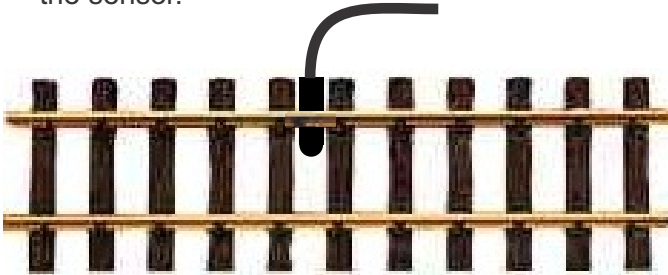

Sensor Placement for identifying a train.

Offset the train's magnet to the same side as the sensor as shown.

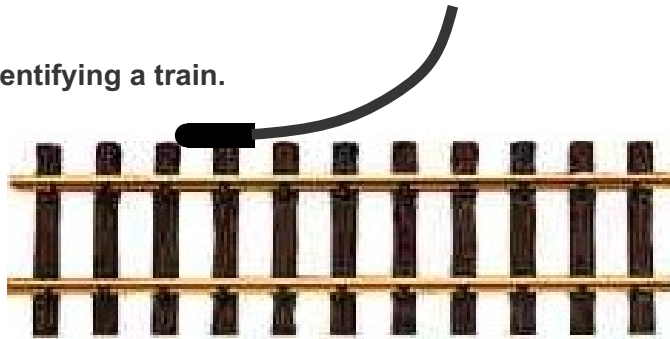

For example, passenger trains have the magnet offset to the right and freight trains have the magnet offset to the left side.

Sensor placement for HO EZ track is under the roadbed.



Other scale trains can place the sensors where appropriate. Very small sensors are available which do not have the waterproof housing. These smaller sensors can be used for N, HO, etc. Contact RR Concepts for these sensors.

WARRANTY

Your StationMaster is warranted, and guaranteed operational for 1 year. It will be repaired or replaced at no charge within that time period. Contact <http://www.RR-Concepts.com> for additional information.