



# StationMaster - 6

## Train Controller

This manual contains detailed hookup and programming instructions for the StationMaster-6 train controller available in a 4 AMP or 10AMP configuration.

The StationMaster-6 can control DC trains or DCC trains when a PWM to DC converter is used.

**Before we Start-** Please do not attach power wires (from your power pack or transformer) to any other terminals except the designated input pins 1 and 2. Your StationMaster will be damaged if power is put on any of the sensor terminals.

### **ONLY ATTACH WIRES WHILE THE POWER IS OFF.**

Quick-connect terminals allow easy swap-out and removal of the electronics while leaving the wires in place. The RR Concepts Magnet/Screwdriver tool is recommended for wire-up and testing of operations.

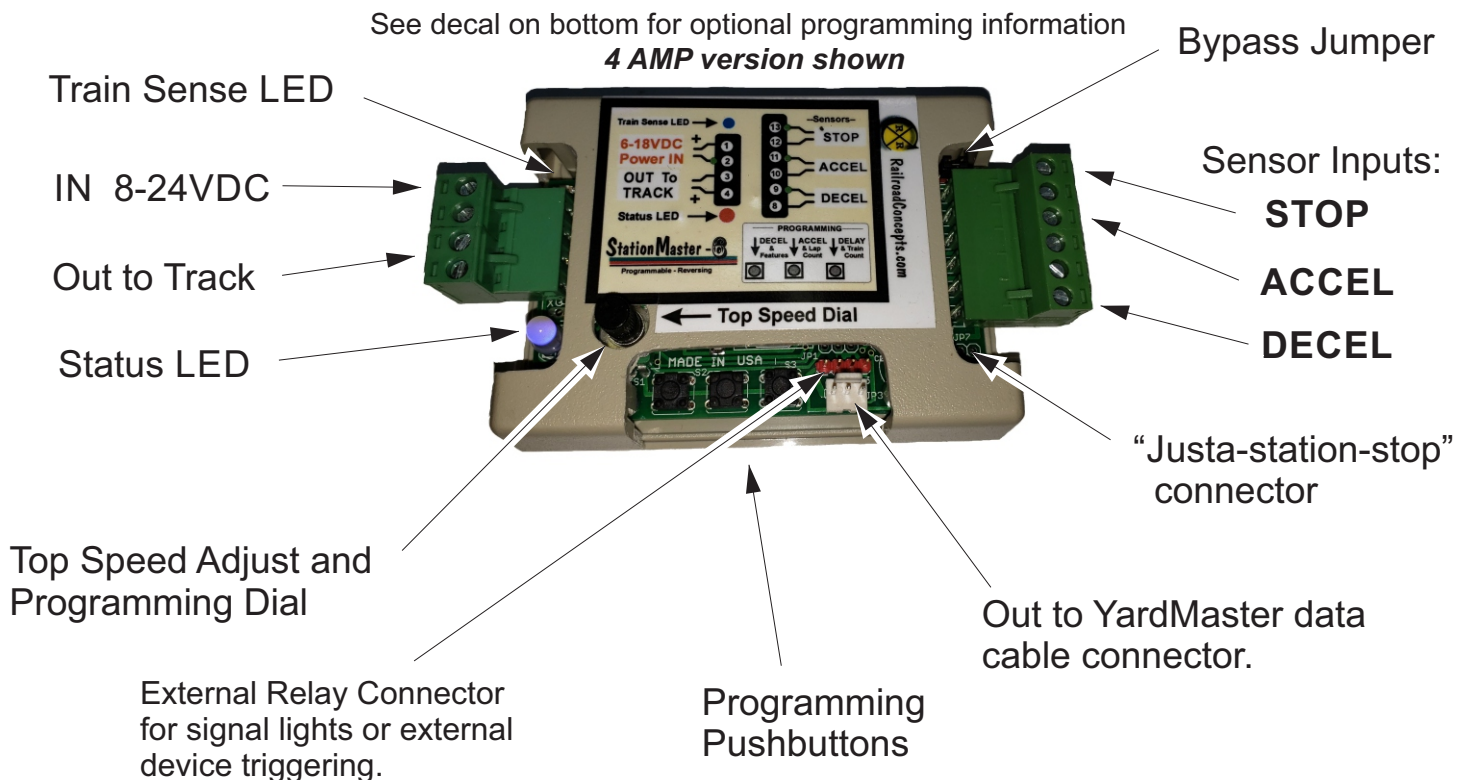

# RR Concepts

## StationMaster - 6

Quick Hookup Instructions

How to do  
**Realistic Station Stops**

### StationMaster CONNECTIONS and CONTROLS

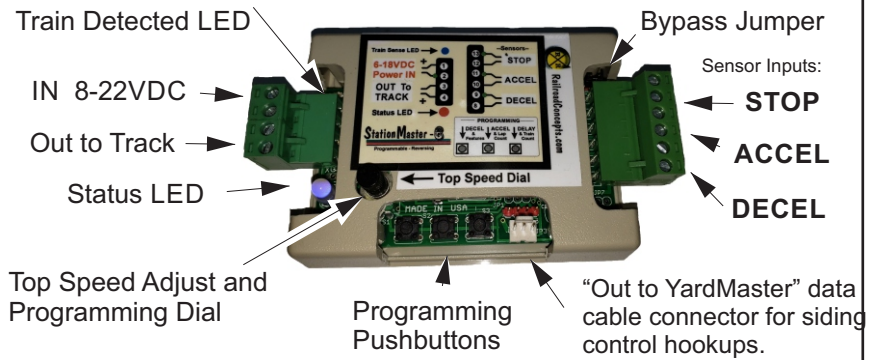

See the label on the bottom for programming and additional information.  
**4 AMP Version shown, Also available in 10 AMP configuration.**

### Station Stop Hookup

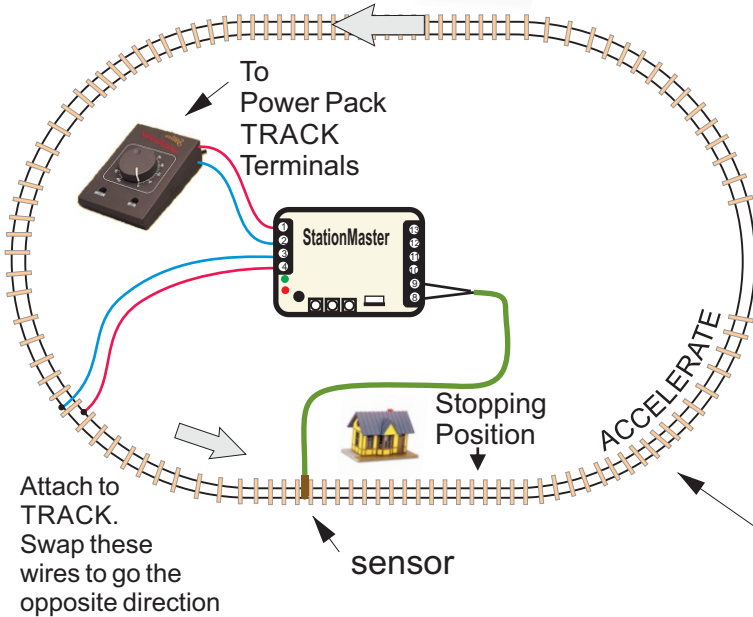

**Un-modified track!  
No diodes, no breaks, no additional track connections.**

### Accelerate + Decelerate Station Stop Hookup

- 1) Attach terminals 1 & 2 to the transformer.
  - 2) Attach terminals 3 & 4 to the track.
  - 3) Attach terminals 8 & 9 to a train sensor. (No polarity)
  - 4) Mount a magnet on an engine or car.
- Set the transformer to the desired top speed. That's it!

#### Optional features include:

- \* Change acceleration rate,
- \* Change deceleration rate,
- \* Add additional station stops,
- \* Do multiple laps before stopping,
- \* Run 2 trains on the same track.
- \* Change station stop pause duration, (Default 10 seconds)
- \* Perform "Self-Adjusting" deceleration. (Requires STOP sensor to stop at an exact location)

## Bypass and Manual Reverse Operation

Sometimes automatic control is not desired so the StationMaster-6 contains a bypass feature.

The SM-6 is shipped with a jumper installed on a 2 pin header, however a bypass switch could easily be installed with a cable that attaches to the header. When the contacts are "open" the SM will be bypassed to allow manual control. When "closed" the SM will be operational.

The SM-6 also allows manual reverse operations. When the input voltage is reverse polarity (train transformer is backing up train) the StationMaster will disengage and allow manual control. **This means that trains can run under manual control when the direction switch on the transformer is "reversed", or the contacts on the header are "open". This will allow you to back up trains if needed.**

## External Relay / Signal Light Control

The StationMaster-6 can control external devices when an Auxiliary relay is attached.

The default setting is for a station stop signal light.

When *decelerating*, *creeping*, or *stopped*, the relay will be ON; for all other cases the relay will be OFF. When a signal light is attached to the relay it could show RED when entering at the station, and GREEN when leaving.

This relay can also be configured to momentarily switch when starting an acceleration or deceleration. This could be used for station sound affects, etc.

See the programming mode page for details.

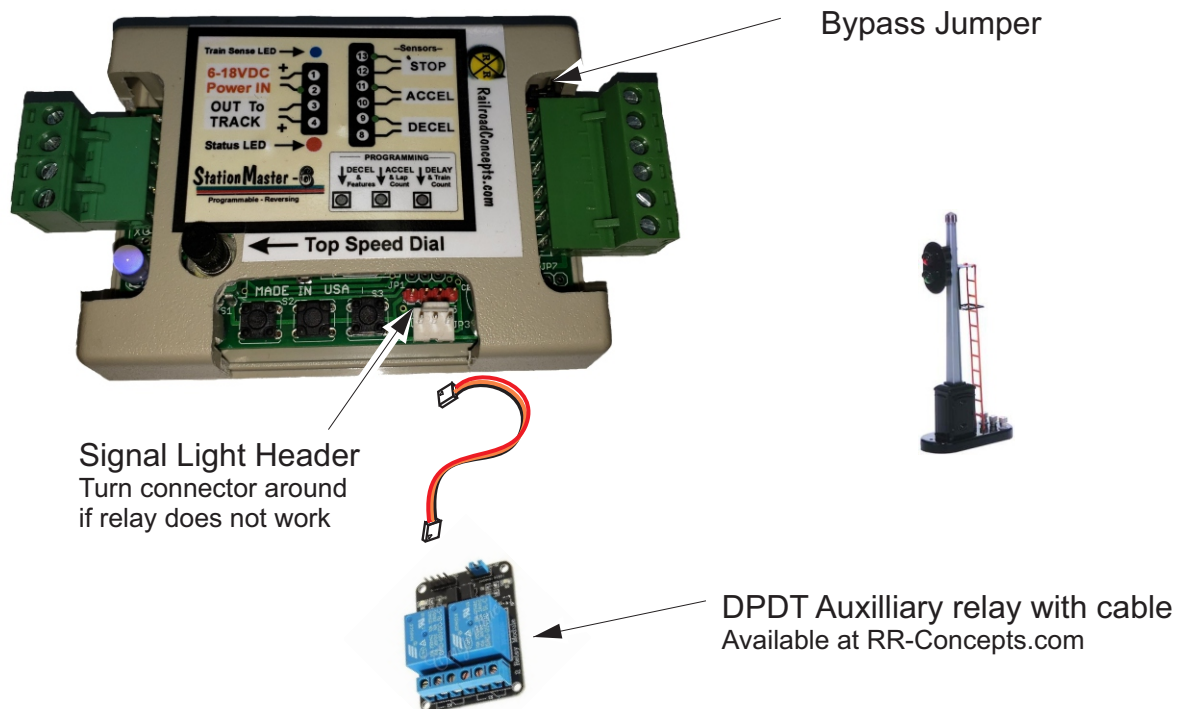

## StationMaster Basic Hookup Description

The StationMaster is designed to be installed between the train transformer, and the track.

Attach terminals 1 & 2 to your transformer's DC output (Sometimes labeled as TRACK) **or** to a 12-22 volt power source. If using a train transformer set the throttle position to the desired top speed of the train. If the StationMaster does not "light up", then the input voltage is reversed OR the bypass jumper is not in place. The SM-6 contains a DC to DC converter so much higher input voltages are possible.

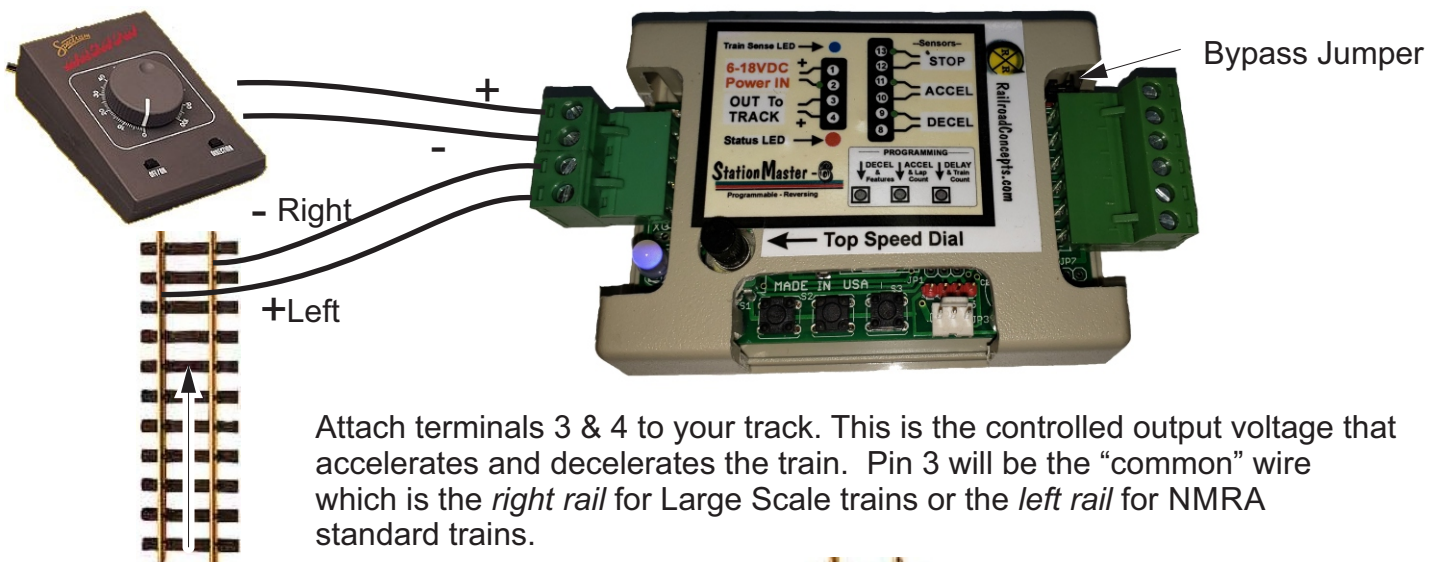

Attach terminals 3 & 4 to your track. This is the controlled output voltage that accelerates and decelerates the train. Pin 3 will be the "common" wire which is the *right rail* for Large Scale trains or the *left rail* for NMRA standard trains.

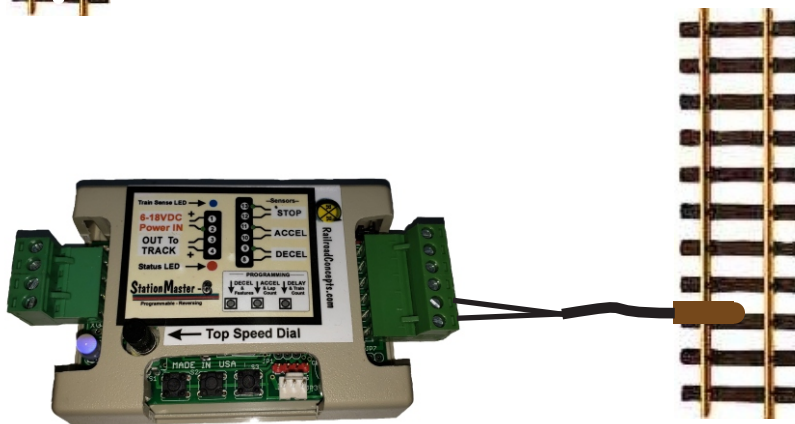

### DECEL Sensor

Terminals 8 & 9 are the **start deceleration** sensor input. When these terminals are closed (sensor detects a magnet) the StationMaster will begin a decelerate, pause, and then accelerate sequence. The LED will turn WHITE for as long as this sensor is detected. By placing multiple sensors wired in parallel, the StationMaster can stop at multiple stations on your railroad.



Pressing button #1 will simulate the DECEL sensor operation.

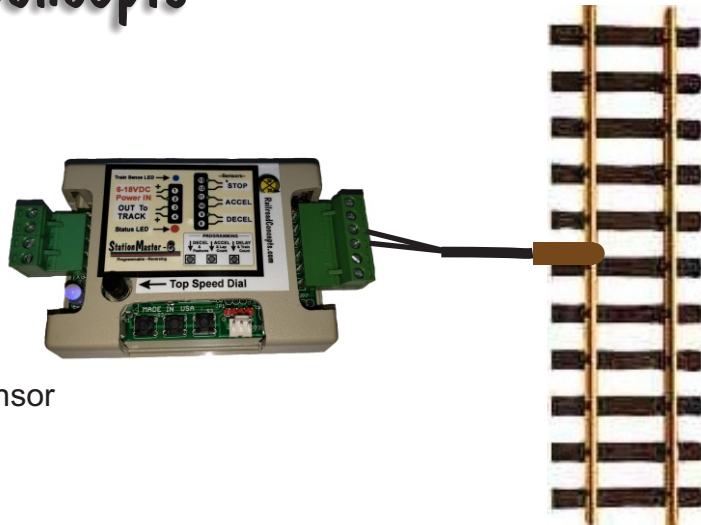

ACCEL Sensor

Terminals 10 and 11 are the optional **Start Acceleration** sensor inputs.

When these terminals are shorted (sensor detects a magnet) the train will start to accelerate.

This sensor is **not** necessary unless using “Block Control” or the **time delay** is set for maximum blinks. (See below).



Pressing button #2 will simulate the ACCEL sensor.

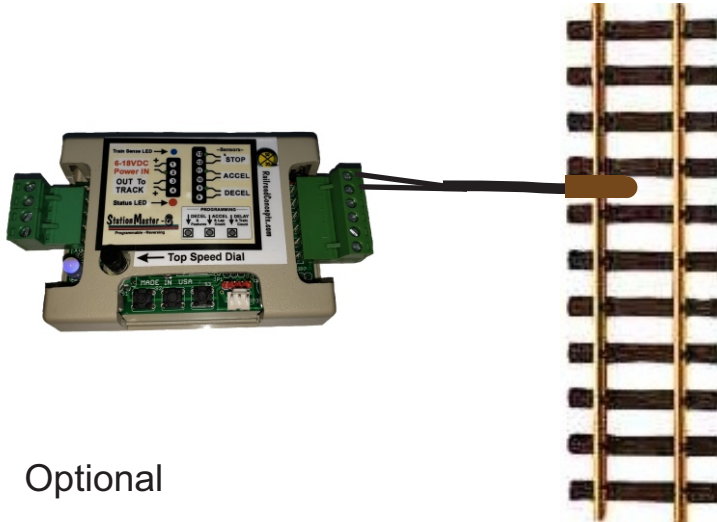

Optional

STOP Sensor

Terminals 12 and 13 are the optional STOP sensor inputs.

**When the train is decelerating** and these terminals are shorted (sensor detects a magnet), the train will immediately STOP. This sensor is not necessary unless using the “Creep Stop Deceleration” mode in which case it is mandatory. **A STOP sensor will have no affect unless the train has already passed over the DECEL sensor.**



Pressing button #3 will simulate the STOP sensor.



## StationMaster “Deadman Timer”

A unique feature of the StationMaster is the *DeadmanTimer*. **If a train is sensed on the track and no sensor has been detected for 10 minutes**, the StationMaster will SHUT DOWN and flash both the Blue train sensed LED and the GREEN status LED.

This prevents the condition where a train is hung up on an obstruction and spinning it's wheels, most probably grinding a divot in the rails and wearing out wheels and gears.

Each time a sensor is triggered, or the train is not sensed, the deadman 10 minute timer is reset.

*The Deadman Timer will be enabled AFTER the first sensor is detected after power up.*

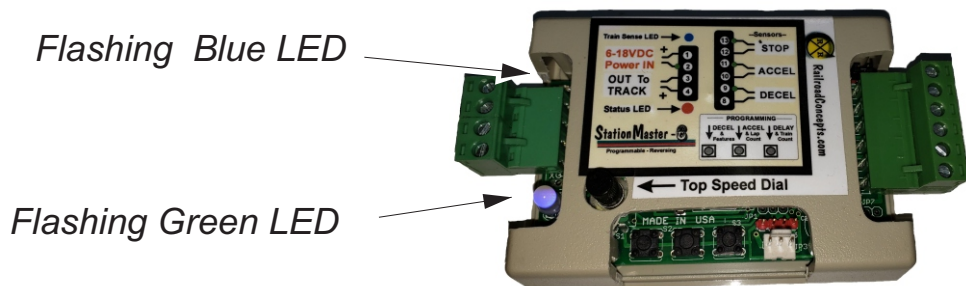

## Top Speed and Programming Mode Dial

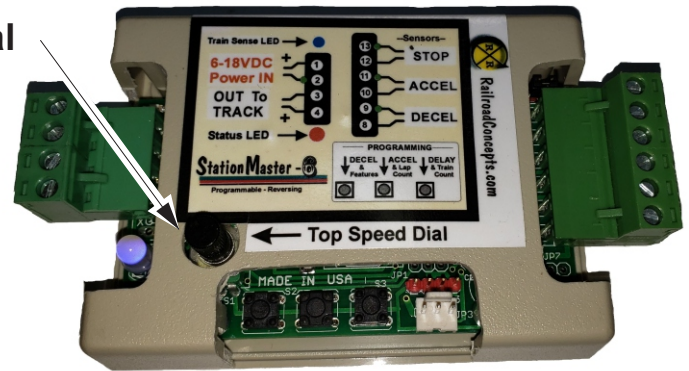

The Top Speed dial provides 2 functions:

- 1: Adjust the top "cruising" speed of the train.
- 2: Enter programming mode.

### Top speed adjustment

"Full speed" is clockwise. Turn this dial down as necessary to set the desired cruising speed of the train. This is only necessary when using a "fixed voltage" power supply or when a YardMaster is attached and a slow top speed is desired.

**Typically, this dial is set fully clockwise and the train throttle (transformer) is used to set the speed of the train.**

### Programming Mode

To enter programming mode turn this dial fully counter-clockwise. The blue Train Detect LED will "twinkle" to indicate "programming mode".

The acceleration rate, deceleration rate and time delay can be programmed in this state. See the programming details or decal on bottom of the StationMaster for additional information.

To exit programming mode turn the dial fully clockwise.

## LED indicators

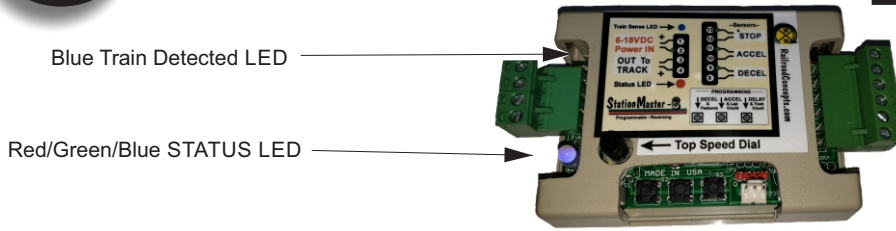

Train Sense LED 

Status LED  **Green:** train is running.

---

Train Sense LED 

Status LED  Fast alternating **Red/Green** Flashing: train is **CREEPING** and hunting for the STOP sensor using the creep speed.

---

Train Sense LED 

Status LED  1. Orange NOT flashing, The StationMaster **will ignore next DECEL sensor** due to lap counting or block control.

Train Sense LED 

Status LED  2. Orange Flashing, The StationMaster is performing a time delay.

---

Train Sense LED 

Status LED  **Red:** Train is **DECELERATING**.

---

Train Sense LED 

Status LED  Status LED WHITE flash: **A sensor is detected**

---

Train Sense LED 

Status LED  Both blinking LED's indicate a SHUTDOWN. **Red = SHORT CIRCUIT, Green = Deadman timer.** To recover: Turn the top speed dial to zero and then back to 100%, press button #1, or cycle power. If condition returns after recovery then check for a short circuit on the track or ***re-program the shutdown threshold by turning transformer to full speed, and pressing button #3 while flashing.***

---

Train Sense LED 

Status LED  A blue Train Sense LED twinkling indicates programming mode.

Status LED  No color is primary programming mode. A GREEN status LED indicates SECONDARY programming mode, and a BLUE LED indicates TERTIARY programming mode.

---



## Programming: Deceleration Rate

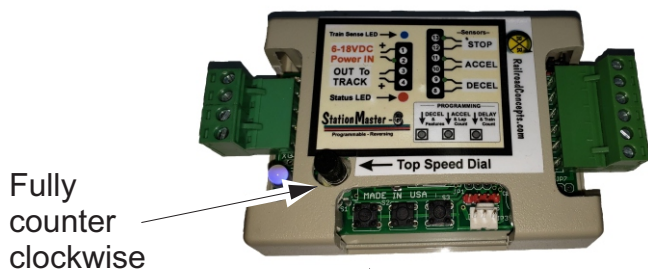

1. Make sure all three sensor inputs are open.
2. If the top speed dial is not already at zero, then turn the top speed dial to zero. (fully counter-clockwise.) The Blue "Train Detected" LED will "twinkle"
3. Push and hold programming button #1.
4. Watch the status led. Each RED blink will decelerate slower.  
**The fastest deceleration will be with one blink.** (TRAIN Stops sooner) Release the pushbutton when the desired number of blinks have occurred. A typical number is 5. Repeat this procedure if you want a different value.

One blink corresponds to a 3 second deceleration rate. Each additional blink adds 1 second. For example, a blink count of 5 would result in a deceleration rate of 8 seconds.



When finished with all programming turn the top speed dial fully clockwise and then turn down to a desired top speed if needed.

All programming values are stored in flash memory and are retained until re-programmed.

## Programming: Acceleration Rate

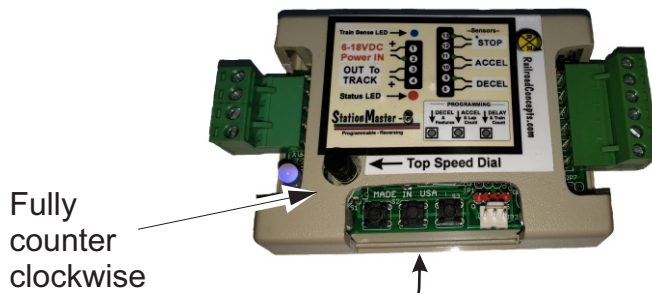

1. Make sure all three sensor inputs are open. (Red LED is off)
2. If the top speed dial is not already at zero, then turn the top speed dial to zero. (fully counter-clockwise.) BlueTrain Detected LED will “twinkle”.
3. Press and hold programming button #2..

4. Watch the status led. Each GREEN flash will accelerate slower.

**The fastest acceleration will be with one blink.**

Release the button when the desired number of blinks have occurred.

A typical number is 5. Repeat this procedure if you want a different value.

One blink corresponds to a 3 second acceleration time. Each additional blink adds 1 second. For example, a blink count of 5 would result in a acceleration rate of 8 seconds. A factory default will set to 5.



When finished with all programming, increase the top speed dial clockwise to MAX and then down to a desired top speed. All programming values are stored in flash memory and are retained until re-programmed.

**A Note on Realistic Accelerations:**

\* For blinks 1 thru 9 the train will accelerate linearly with the programmed value. This may be required for some block control operations where a second train is approaching and the first train needs to quickly accelerate to get out of the way, or for a trolley which accelerates quickly.

\* For blinks 10 and above the train will creep very slowly out of the station and then continue accelerating as it continues down the main line. This provides a very realistic operation as a train creeps out of a siding or station and shows off sound systems with incredible realism.

\* 10 blinks will creep for 5 seconds.

\* 11 blinks will creep for 10 seconds.

\* 12 blinks and up will creep for 15 seconds.



# RR Concepts

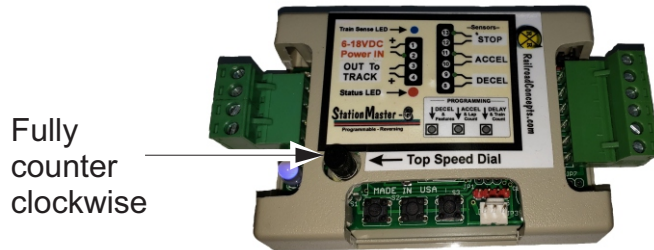

Fully counter clockwise

## Programming: Pause Time

1. Make sure all three sensor inputs are open. (red Led is off)
2. If the top speed dial is not already at zero, then turn the top speed dial to zero. (fully counter-clockwise.) BlueTrain Detected LED will “twinkle”.
3. Press and hold programming button #3.
4. Each ORANGE flash will increase the waiting time after a station stop. A wait time of zero will be with one flash. Release the button when the desired number of flashes have occurred. Repeat this procedure if you want a different value.

The LED will turn orange when an infinite delay is set (after 13 counts).

**When infinite delay is set, then the ACCEL sensor is required to start up the train after a station stop.**

A fun thing to do would be to connect the ACCEL terminals to a doorbell switch. Your train would patiently wait until someone pushed the button! Motion sensors are another possible way to start the train.

When finished with all programming increase the top speed dial clockwise to maximum or to a desired top speed. All programming values are stored in flash memory and are retained until re-programmed.



The number of orange FLASHES will correspond to the following time delays:

- 1: 0 seconds, no wait.
- 2: 5 seconds
- 3: 10 seconds
- 4: 15 seconds
- 5: 20 seconds
- 6: 30 seconds
- 7: 1 minute
- 8: 2 minutes
- 9: 5 minutes
- 10: 10 minutes
- 11: 30 minutes
- 12: 60 minutes
- 13: Infinite, wait for ACCEL sensor. This is for block control operations.

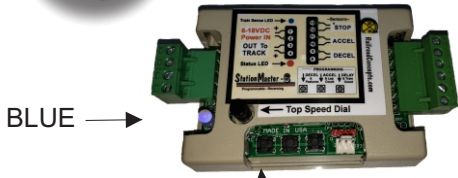

Please go to [RRconcepts.com](http://RRconcepts.com) to view an informational video on how to program operating modes.

## Programming: Operating Modes

HOW TO PROGRAM: (Perform a factory reset to clear everything)

1. **Enter Secondary Programming mode:** (Skip this step if already in secondary programming mode)

- \* Turn the Top Speed dial fully counter-clockwise to enter programming mode (Skip this step if already in programming mode).
- \* Turn the Top Speed dial slowly clockwise until the sensor LED turns green. This indicates secondary programming mode. This should be about half-way.

2. **Press and hold programming button #1** until the desired number of blinks have occurred. Each blink will set or clear a different feature. If currently ON it will turn off. If OFF it will turn ON.

**When finished do not power off without first turning the dial fully clockwise.**



**Programmable Modes: (Any or all of these or all can be programmed independently)**

- Hold button for 1 blinks = Fire YardMaster before acceleration. (Default ON for reversing mode)
- Hold button for 2 blinks = Fire YardMaster after train has stopped. (Set after factory reset)
- Hold button for 3 blinks = Use automatic train detection to start deceleration. (No-sensor station stops)
- Hold button for 4 blinks = Shut off current sensor. This could cause damage to the StationMaster unless the transformer can provide short-circuit shutdown. This is sometimes necessary when running with very small transformers. (1 AMP or less)
- Hold button for 5 blinks = Enable "Alternate Opposite mode". See hookup in this manual for alternating trains in opposite directions.
- Hold button for 6 blinks = Turn on "creep stop". The train will decelerate then creep until reaching the STOP sensor. LEDs will flash RED/GREEN when creeping.

When the button is released the StationMaster will echo the currently programmed features (modes) by blinking the red/green LED 5 times. *For example*, if "Fire YardMaster after train has stopped" has been programmed (button pressed for 2 blinks, or after factory reset) and nothing else is programmed then the StationMaster will blink:

- blink 1 RED: Fire YardMaster before acceleration OFF
- blink 2 GREEN: Fire YardMaster after stopping ON
- blink 3 RED: Use train sensor to start deceleration OFF
- blink 4 RED: Disable current sensor: OFF
- blink 5 RED: Alternate opposite mode : OFF
- blink 6 RED: Creep-stop mode : OFF

Each time a feature is programmed that feature will toggle on or off. (Toggle means the feature will go OFF if currently ON, or ON if currently OFF). A factory reset will clear all values and set blink 2.

**To view the currently programmed operating modes quickly press and release button #1.**

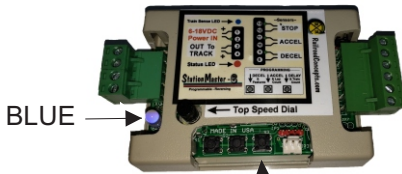

Please go to [RRconcepts.com](http://RRconcepts.com) to view an informational video on how to program operating modes.

## Programming: Aux Relay Control

The external auxiliary relay can be programmed to behave in four different manners. These include:

- \* **Station Stop mode where the relay will turn on while entering the station and stopped.**
- \* **Trigger mode, where the relay will “pulse” just after stopping.**
- \* **Trigger mode where the relay will “pulse” just before accelerating.**

HOW TO PROGRAM: (Perform a factory reset to clear everything if needed)

1. **Enter Tertiary Programming mode:** (Skip this step if already in tertiary programming mode)

- \* Turn the Top Speed dial fully counter-clockwise to enter programming mode (Skip this step if already in programming mode). The blue Train Detected LED will “twinkle”
- \* Turn the Top Speed dial slowly clockwise until the sensor LED turns Green and then **BLUE**. This indicated tertiary programming mode. (Only available on software after 09-2019)

2. **Press and hold programming button #3** until the desired number of blinks have occurred.

**When finished do not power off without first turning the dial fully clockwise.**

### Programmable Modes:

- Hold button for 1 blink = Station Stop mode, Perfect for a signal light.
- Hold button for 3 blinks = Pulse at stop
- Hold button for 4 blinks = Pulse at acceleration start

To view the currently programmed operating mode quickly press and release button #3.

### Additional notes for usage:

- \* The “pulse” modes could be used to trigger an external sound module or other device.
- \* It is also possible to use this header to directly trigger another StationMaster or YardMaster without the relay. For example, just as one StationMaster stops a train it could then trigger a second StationMaster to start up. Consult RR concepts for details.

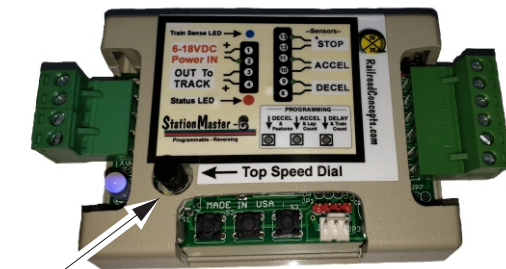

Fully  
counter  
clockwise

## Programming: Factory Reset

To set the StationMaster back to factory defaults perform the following:

- 1: Enter programming mode by turning the top speed dial fully counter-clockwise
2. Press and hold both button #1 AND button #3 at the same time.
- 3 Turn the top speed dial fully clockwise to exit programming mode.



**Do not power off without first turning the dial fully clockwise.**

The factory default settings are:

- \* Acceleration rate 5 blinks
- \* Deceleration rate 3 blinks.
- \* Time delay 5 seconds.
- \* Train count: 2 (Note: Block control will not be operation until set for 1 train)
- \* Lap count: 1
- \* Operating mode (features):

Blink 1 = RED, Fire YardMaster before accelerating: OFF  
 Blink 2 = GREEN, Fire YardMaster after train has stopped: ON  
 Blink 3 = RED, Use train sense to start deceleration: OFF  
 Blink 4 = RED, Disable current sensor: OFF  
 Blink 5 = RED, Alternate Opposite mode: OFF  
 Blink 6 = RED, Enable CREEP-STOP mode: OFF

**With these settings both the *Simple Station Stop*, and the *Alternating Trains* hookups are ready to run!**



## Programming: MULTIPLE LAPS

1. Turn the Top Speed dial fully counter-clockwise to enter programming mode (Skip this step if already in programming mode).
2. Slowly turn the Top Speed dial clockwise until the GREEN LED turns on. This indicates secondary programming mode. (Skip this step if already in secondary programming mode)
3. Press and hold button #2.
4. Count the blinks while the button is pressed. Release the button when the appropriate number of blinks (LAPS) are set.



When finished with all programming turn the top speed dial clockwise to maximum.

All programming values are stored in flash memory and saved until re-programmed again.



## Programming: Train Count

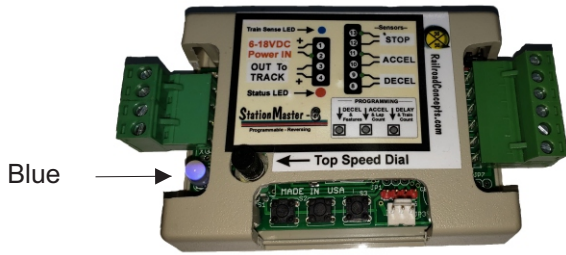

The train count is needed for 3 reasons:

1. Manage different creeping speeds for up to 5 trains.
2. Send proper signals to attached YardMasters to correctly fire turnouts.
3. Allow running in a block-control mode. (Must be set for 1 train)

For example, a 3 track siding using 2 YardMasters wired in parallel would have a train count of 3, since 3 trains will be controlled.

A factory reset will set this to 2 trains.

For an alternating siding hookup a factory reset will set this correctly.

### Programming:

1. Make sure all three sensor inputs are open.
2. If not already in programming mode turn the top speed dial to zero. (fully counter-clockwise.)
3. Slowly turn the top speed dial clockwise until the sensor LED turns GREEN. This indicates secondary programming mode. (Skip this step if already in secondary programming mode)
4. Press and hold button #3.
5. Each orange flash counts the number of running trains.

Release the button when the desired number of flashes have occurred.

The number will be echoed back when the button is released..

Repeat this procedure if you want a different value.



When finished with all programming, increase the top speed dial clockwise to MAX, and then down to a desired top speed if necessary.

All programming values are stored in flash memory and saved until re-programmed again.

**NOTICE: A factory reset will set the train count to 2.** Block control will not be operational until set for 1 train.



## “Justa Station Stop”

Justa-Station-stop performs a decelerate/Pause/Accelerate sequence *without* triggering an attached YardMaster or reversing.

When operating in an *alternating trains* hookup, additional stations stops can be done at different locations around the loop without affecting the parked train.

Add a 3 pin plug into the bottom right 3 pin header and attach the sensor to pins 1 and 3.

The Deceleration rate, Acceleration rate, and pause times are FIXED.

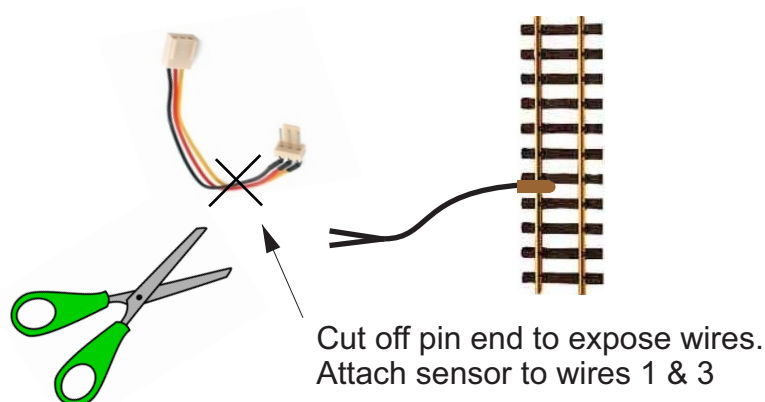
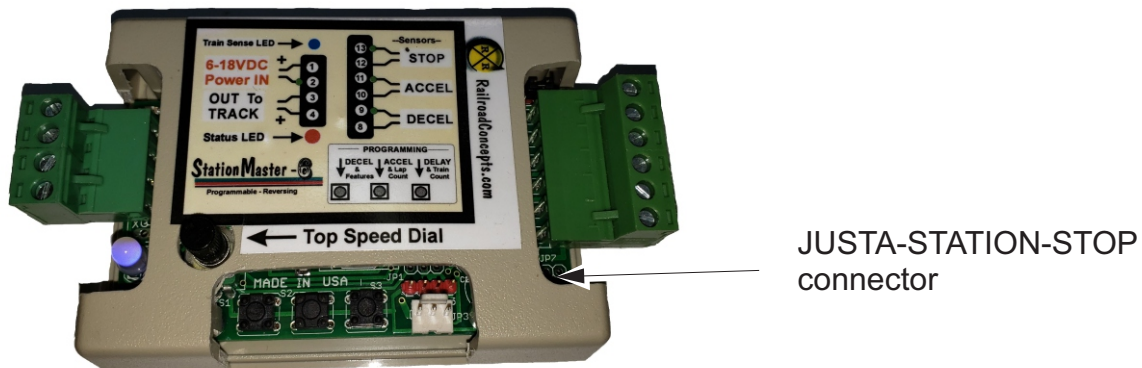



# RR Concepts

## Basic Hookup Diagram for Automatic Station Stops with Deceleration/Acceleration using train sensors.

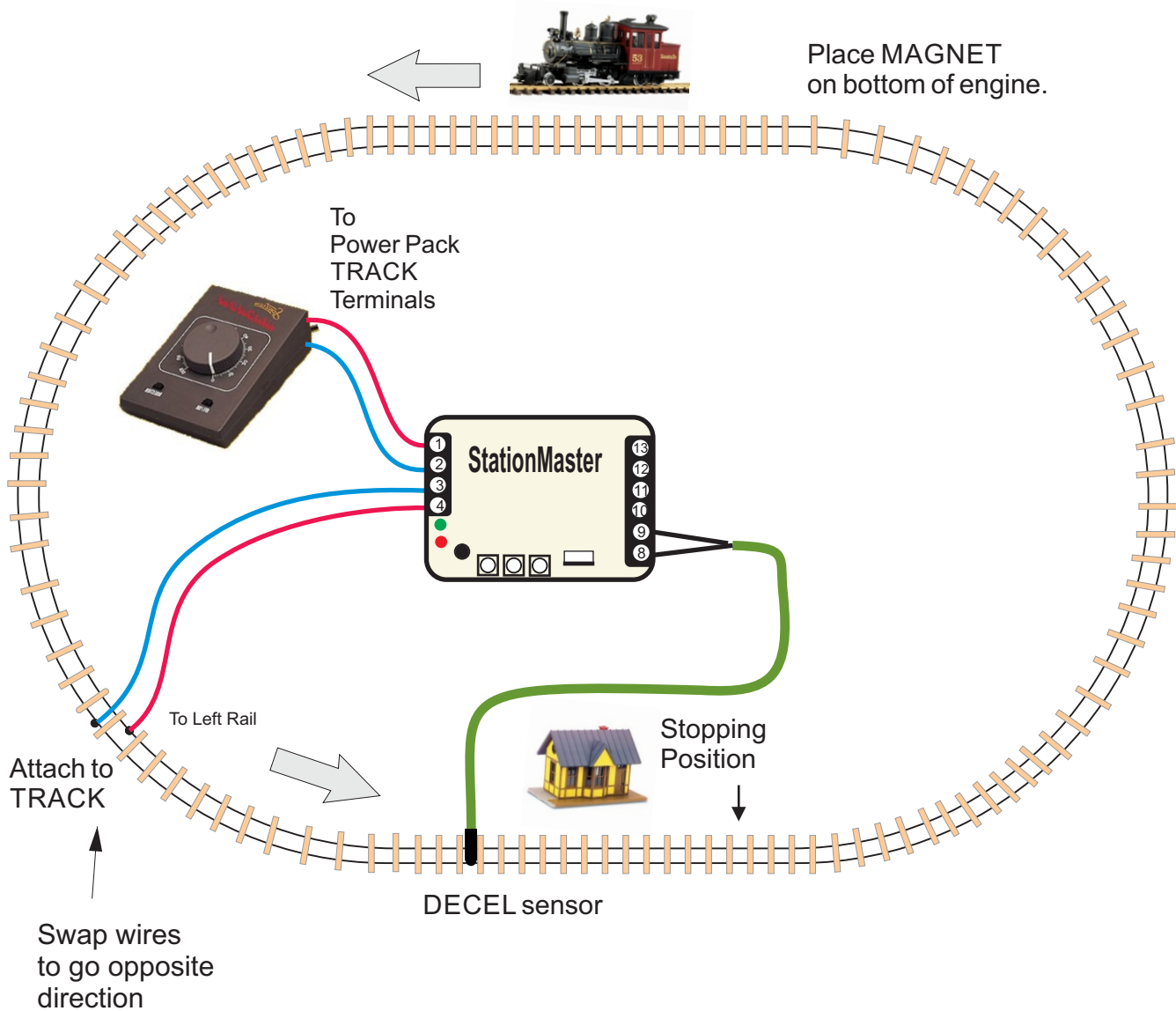

For a simple station stop, this is all you need to do!  
 Factory settings will be a gradual acceleration, gradual deceleration and 10 second stop.

# RR Concepts

## Multiple Station Stops

Your train can stop at many stations on the loop by adding DECEL sensors in parallel.

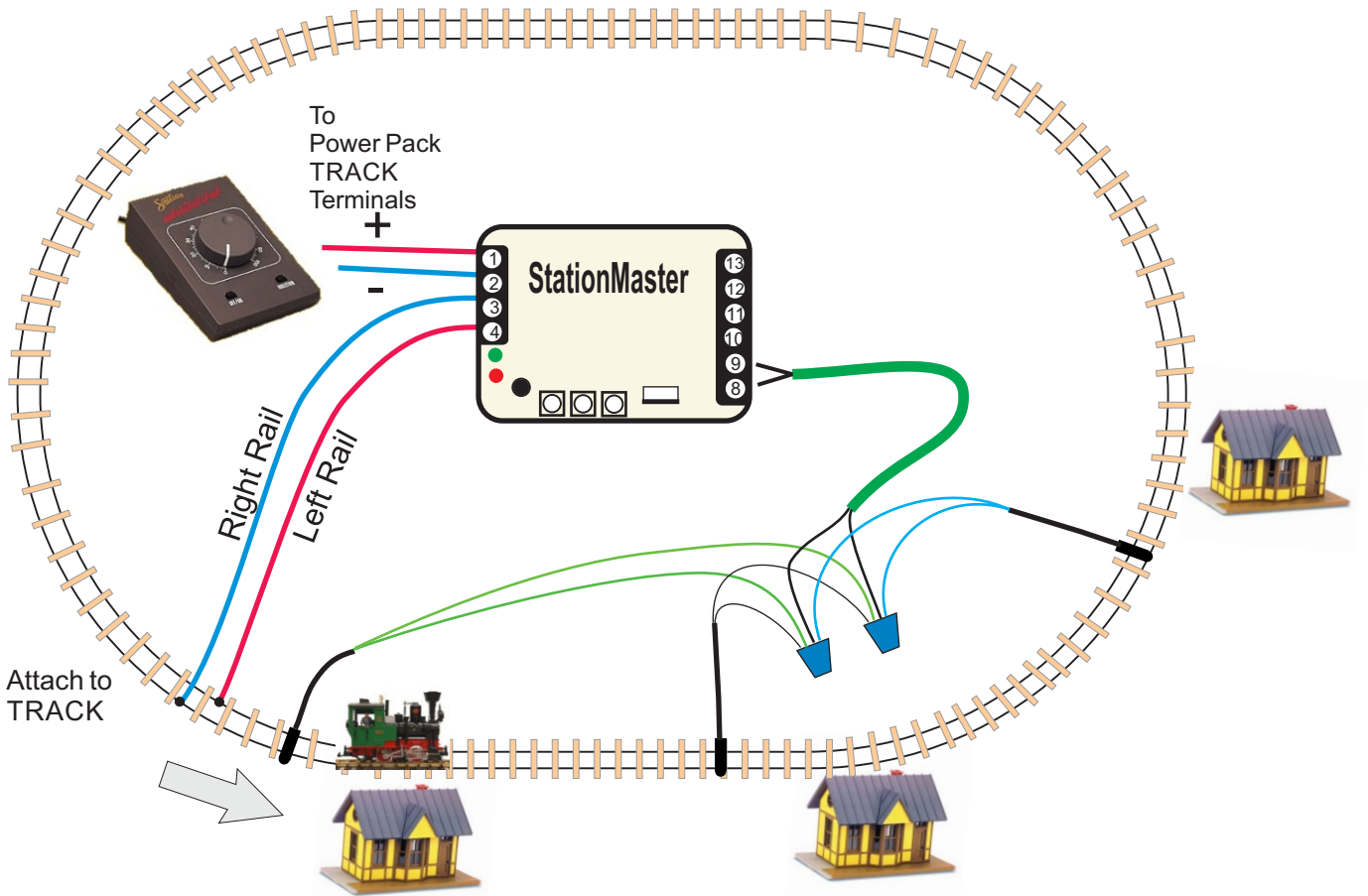

Every sensor that the train passes over will cause a decelerate/pause/accelerate sequence.



## Two Trains on One Track - Block Control

For two trains on a loop with gradual decelerations and accelerations.

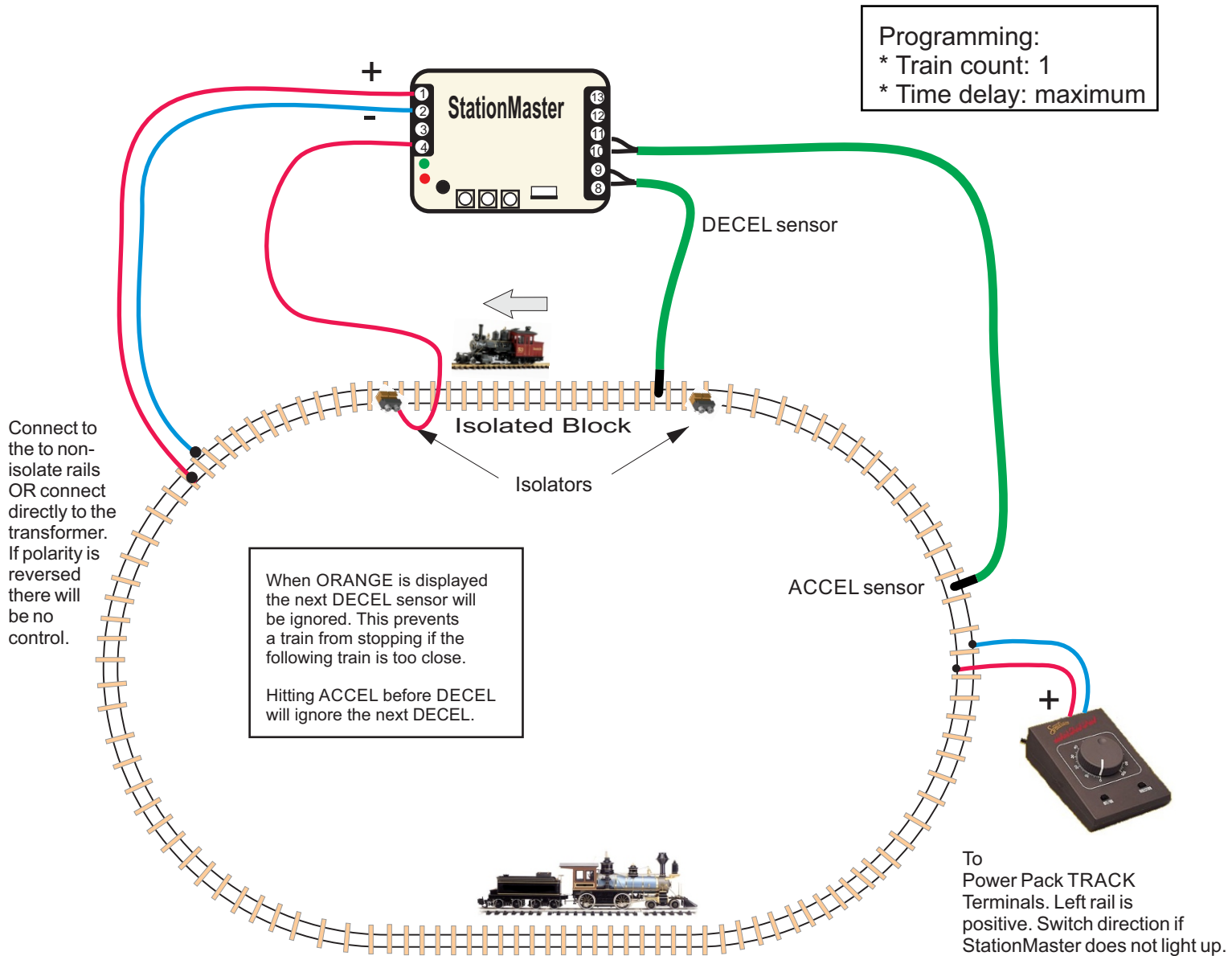

### Hookup Notes:

1. The train may not stop if the following train is too close. (This is a good thing)
2. When the train decelerates it must stop before exiting the block. Adjust the deceleration time as needed.
3. This hookup will run continuously when one train is on the track. (One train will perform a timed station stop when the ACCEL sensor is removed, and the time delay is not maximum.)
4. A longer isolated section will provide more realism for deceleration and acceleration.
5. The StationMaster can be located at a remote location on your railroad.
6. When the transformer direction is reversed, the StationMaster will dis-engage to allow manual control.

### TIP:

The location of the ACCEL sensor determines how long a train will wait at the block:

- \* When closer to the block the pause will be longer.
- \* When farther away both trains will run for a longer amount of time.

# RR Concepts

## Block Control

For 1, 2, or 3 Trains on 1 track with gradual Decelerations and Accelerations using StationMasters.

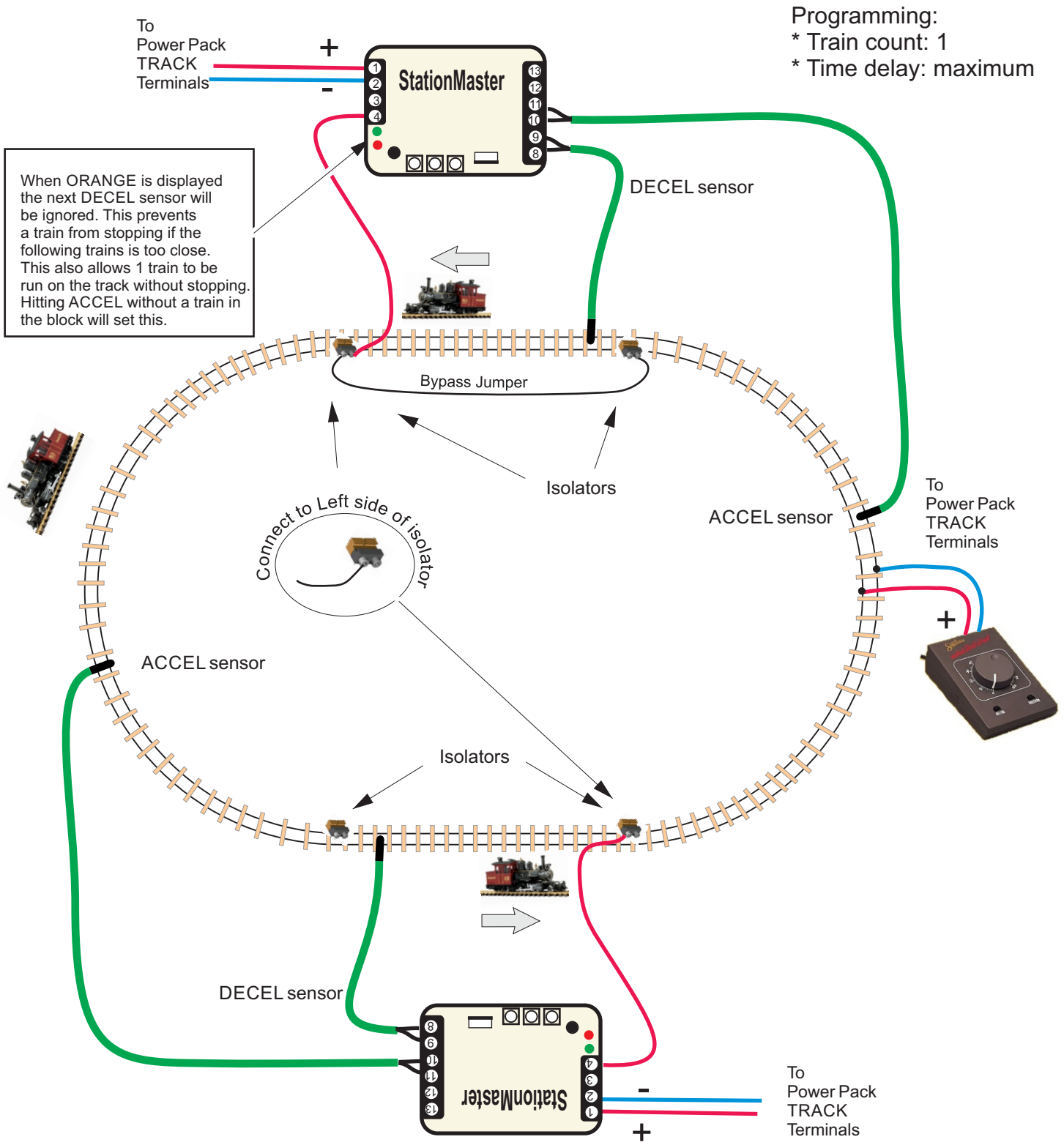



# RR Concepts

## No Sensor Station Stop

Using the Automatic Train Detection feature.

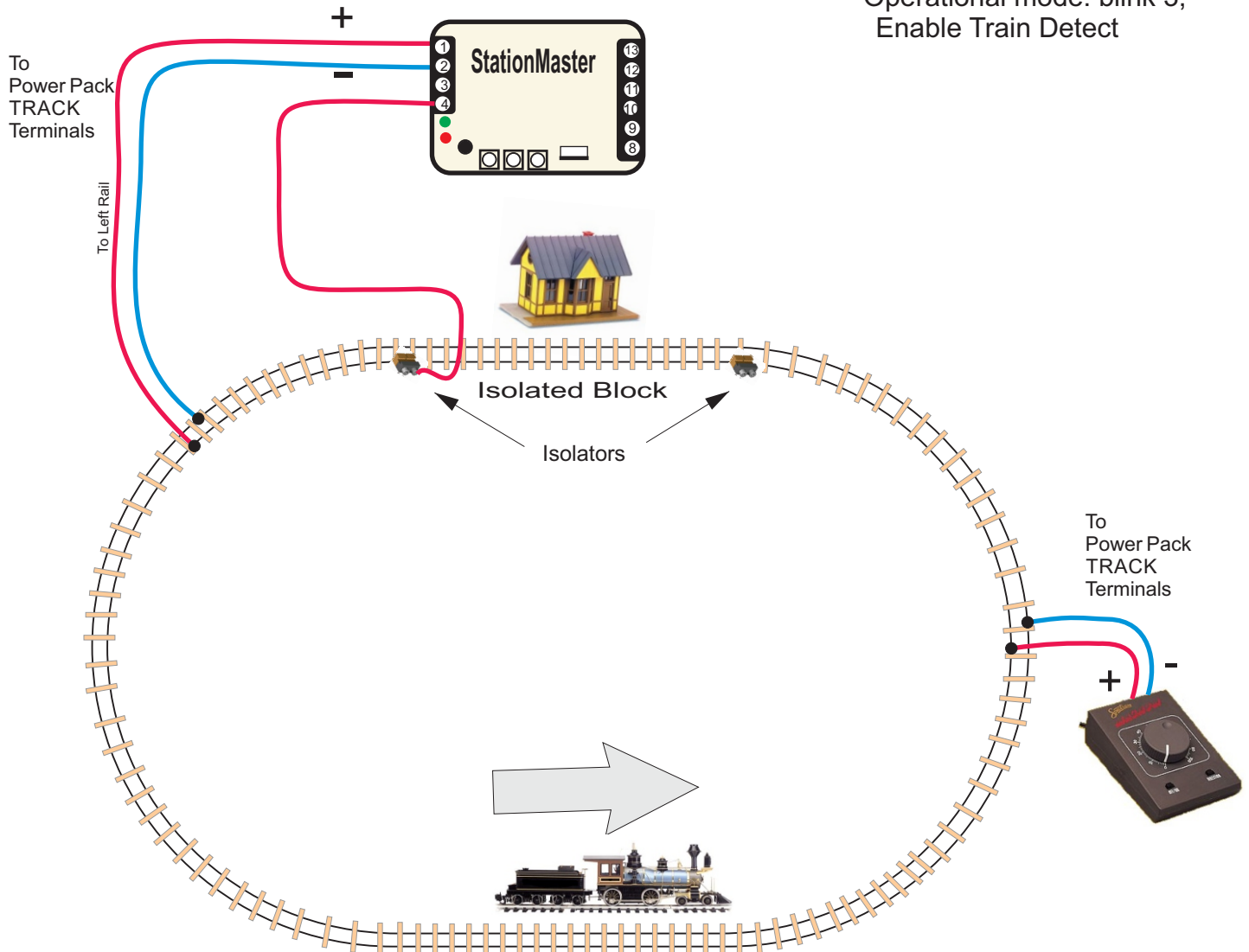

### Programming:

\* Operational mode: blink 3,  
Enable Train Detect

### Hookup Notes:

1. Isolated section must be long enough to allow the train to decelerate and accelerate.
2. Train can only go in one direction.
3. Program Operational Mode for "blink 3". Train detection
4. Program time delay as desired.
5. No magnets or sensors are required
6. Station stop can be located at a remote location on your railroad far from the transformer..
7. When the input voltage is reversed the StationMaster-6 will dis-engage and allow full manual control and the train will run backwards without stopping.

## “Creep-Stop” Deceleration for Incredible Realism

A unique and extremely realistic feature of the StationMaster is “Creep-Stop” Deceleration. By using both a DECEL sensor and a STOP sensor the StationMaster will provide a very realistic self-adjusting station stop. Programming your StationMaster to use “Creep-Stop” is very easy:

1. Set bit 8 in programming mode.(Press and hold button #1 in SECONDARY Programming mode until the for 8 blinks and the LED blinks rapidly)
2. Place the **DECEL** and **STOP** sensors on your track as shown. The distance between sensors should be about 2 to 6 feet, or whatever looks good to you.
3. Optional: Program a deceleration rate to provide a realistic deceleration into the train yard before the creep starts.

**That's it!**

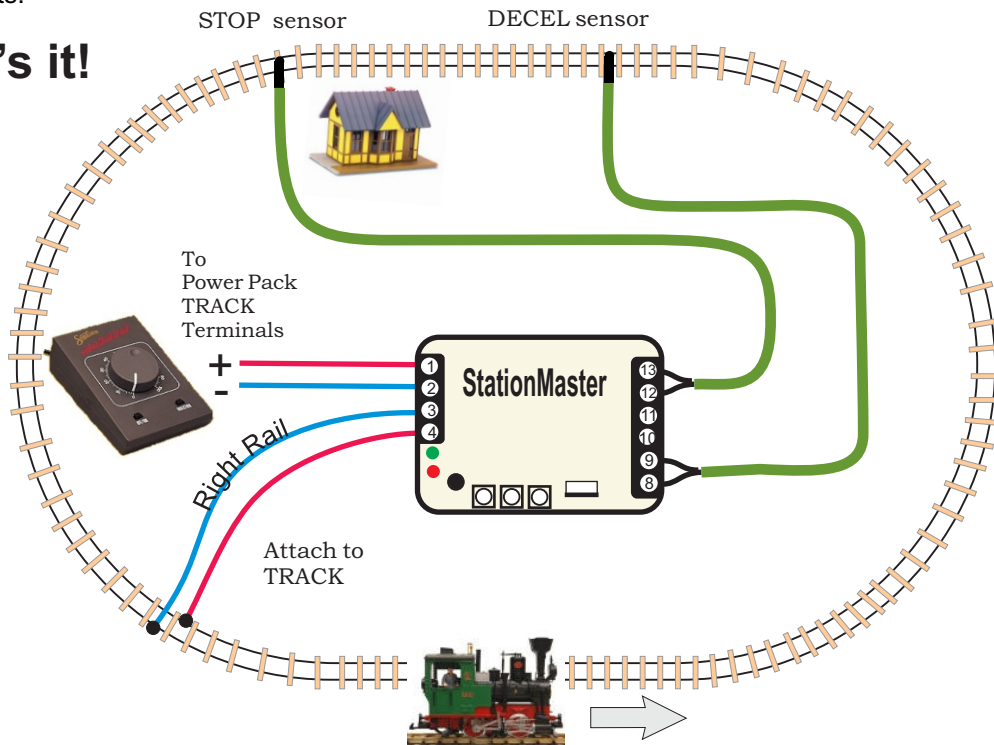

When “Creep Stop” is enabled, the train will self-adjust the deceleration rate and creeping speeds each time the DECEL sensor is hit. The train will always “creep” forward until the STOP sensor is reached, and adjust the deceleration rate based on the distance between the DECEL and STOP sensors. This guarantees the train will always stop on the STOP sensor using a realistic profile.

The starting creep speed will be relatively slow, and the StationMaster will re-adjust the creep speed if the STOP sensor is not reached within 25 seconds. If the train stalls, (which is expected most of the time when first starting to adjust) then the creep speed will be increased for the next time. Don’t touch the train if it stalls! After 25 seconds the train travel to the STOP sensor. Eventually the train will not stall.

Adjusted creep speeds and deceleration rates are stored in flash memory and retained until reset by entering programming mode.

The length of the creeping can be adjusted by either increasing or decreasing the distance between DECEL and STOP sensors. Start with a 4 foot distance and see how that looks.

Up to 5 different creep speeds can be used for 5 different trains. Slow trains can run next to fast trains and each will creep perfectly, Use the “train count” to set the number of trains that will be run. A factory default will set for 2 trains which is perfect for an alternating siding setup.



## Alternating Trains in Opposite Directions SPRING-RETURN TURNOUTS

### TRACK CONNECTIONS

Realistic accelerations, self-adjusting decelerations

— Parts List —

- 1 StationMaster-6
- 4 Track Isolators
- 1 Alternating Trains Hookup Kit
  - Includes: 4 Sensors
  - 2 Magnets
  - 2 Diodes

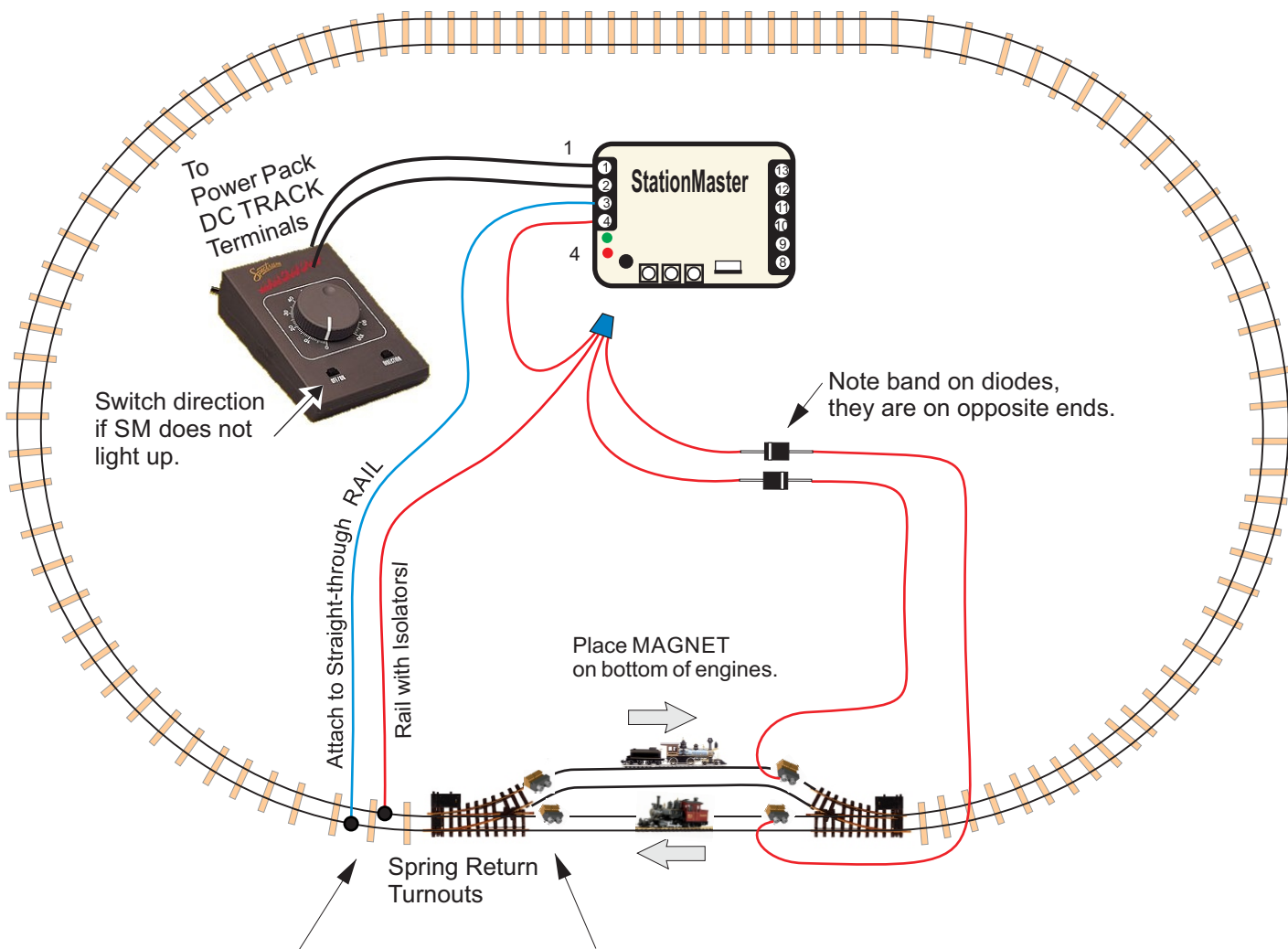

Switch direction if SM does not light up.

Note band on diodes, they are on opposite ends.

Place MAGNET on bottom of engines.

Spring Return Turnouts

These are just connections to the rails. The BLUE rail should be connected all around.

Track isolators, 4 Required. On one of the rails of each siding as shown.

Split-Jaw isolators shown, LGB or others can also be used.



Remove brass connectors if needed and replace with isolators.

If powered turnouts are necessary use the StationMaster + YardMaster hookup

## Alternating Trains in Opposite Directions SPRING-RETURN TURNOUTS

### SENSOR CONNECTIONS

Realistic accelerations, self-adjusting decelerations

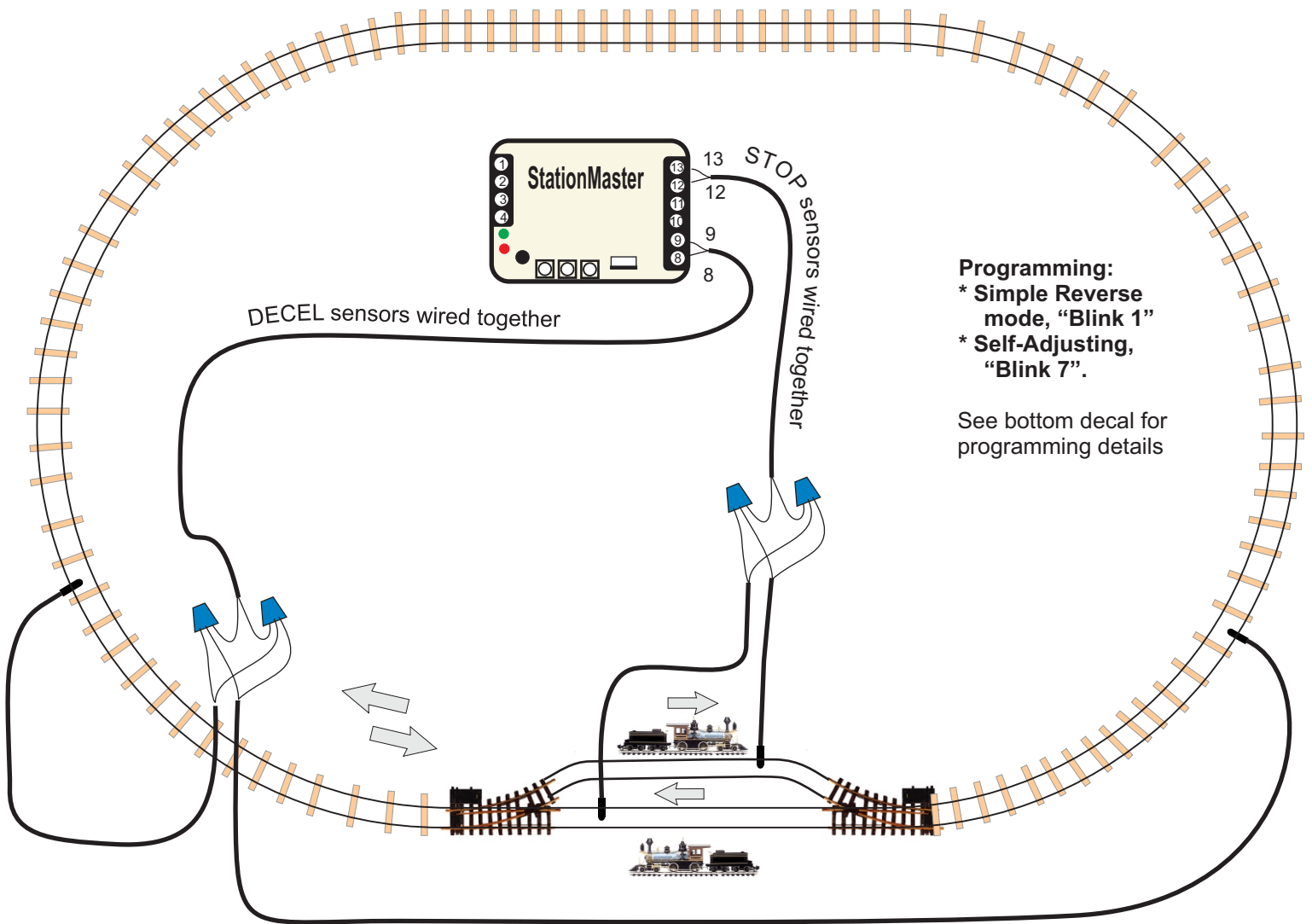

**Programming:**  
 \* Simple Reverse mode, "Blink 1"  
 \* Self-Adjusting, "Blink 7".

See bottom decal for programming details

For additional station stops around the loop see "Justa-Station-Stop" in the StationMaster manual.

## Alternating Trains in Opposite Directions

### More Details...

#### Parts Required:

StationMaster:	Qty 1	4 AMP or 10AMP version.
Turnouts:	Qty 2	(Both spring return)
Track Isolators:	Qty 4	
Magnets:	Qty 2	(or one per train)
Sensors:	Qty 4	
Diodes:	Qty 2	

#### Description

The Alternating 2 train siding will allow 2 trains to run around the layout in opposite directions. One of them will always be in the siding while the other train will be traveling. Trains will realistically decelerate and then creep into the station.

#### StationMaster Hookup:

Terminals 8 and 9 are the DECEL sensor inputs and attach to the DECEL sensor as shown. (No polarity) Each sensor is located where the deceleration will start. Sensors are wired in parallel.

Terminals 12 and 13 are the STOP sensor. Attach these to the STOP sensors in each siding wired in parallel as shown. (No polarity) The train will stop just past this sensor.

Terminals 1 and 2 attach to the transformer. Change the train direction on the transformer if the StationMaster does not light up.

Terminal 3 attaches to RIGHT RAIL which is common ground throughout.

Set the transformer to the desired top speed of the train.

#### StationMaster Programming:

- 1) Start with a factory reset for all values
- 2) Program for "Alternate Opposite Mode" and "Creep Stop"

#### Optional Programming:

- \* Add Multiple laps before stopping.
- \* Change the Acceleration Rate.
- \* Change the Pause time at the station.

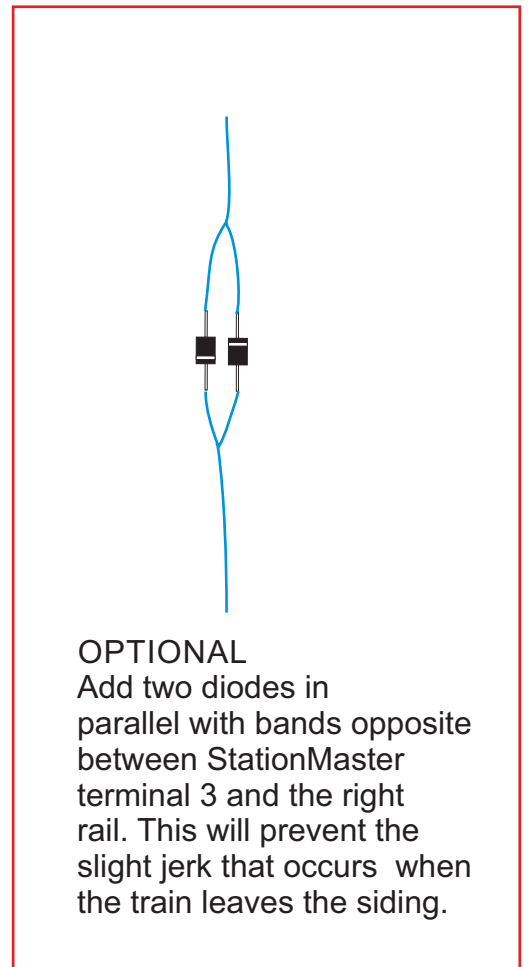

## Alternating Trains

### Powered Turnouts

Two trains take turns with a time delay station stop.

### TRACK CONNECTIONS

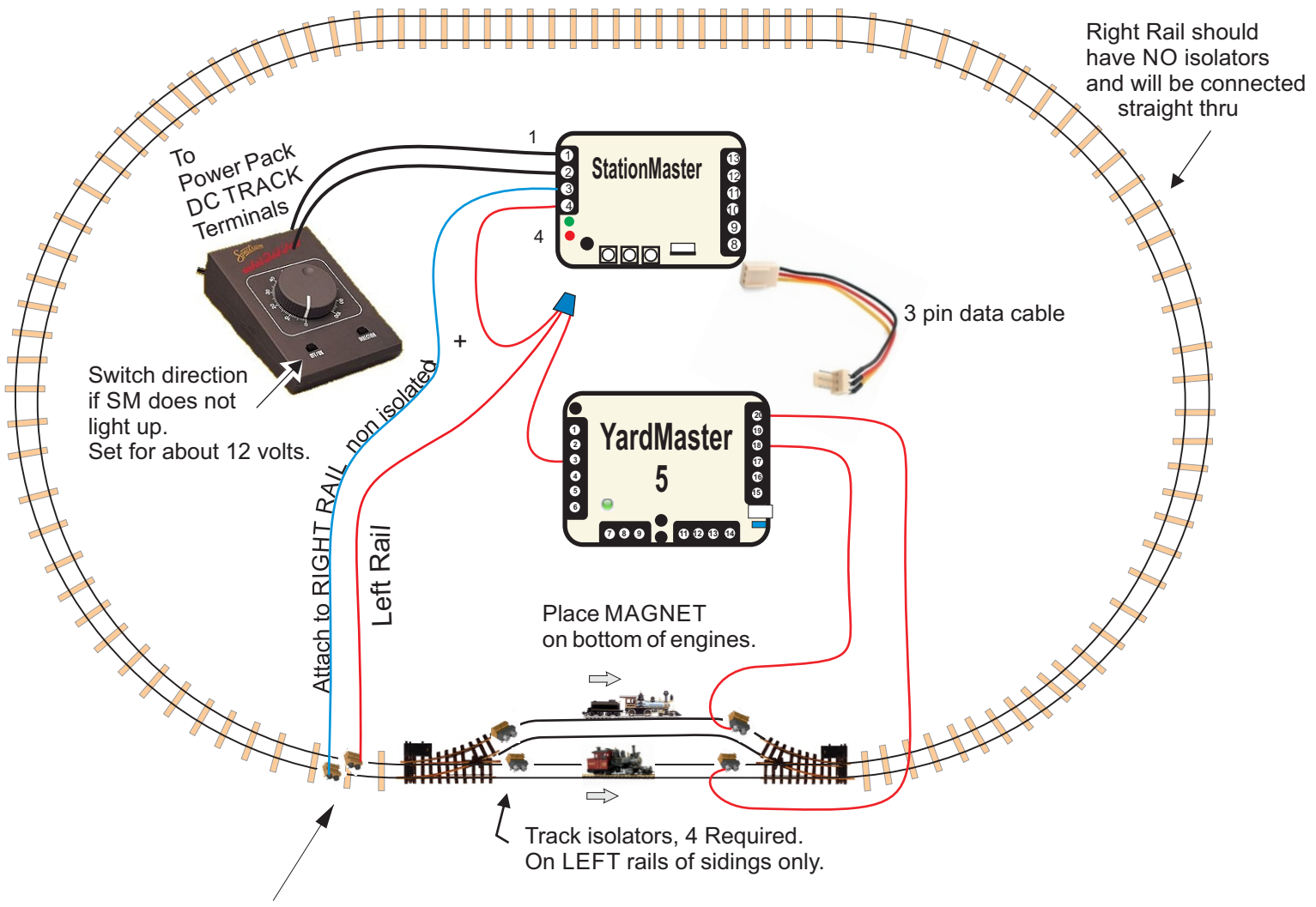

These are just connections to the rails. Non isolated. The right rail should be connected all around.

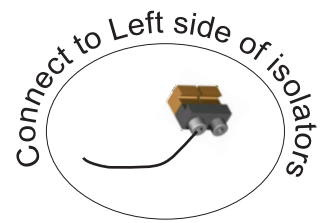

## Alternating Trains Powered Turnouts

### SENSOR CONNECTIONS

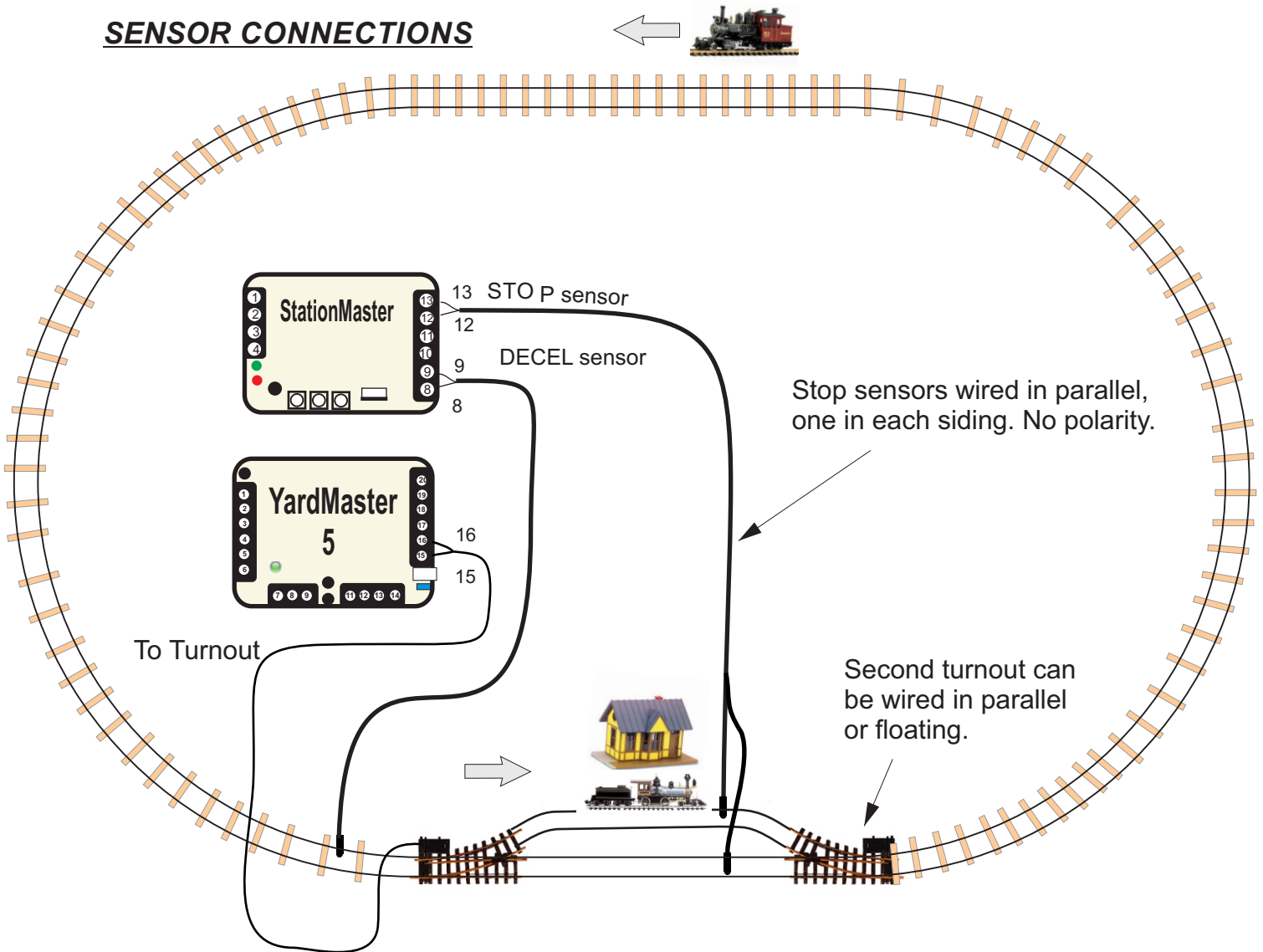

### OPERATIONS

\* Two trains will take turns running on the loop using an optional lap count. When the train has stopped the next train will run after the time delay.

### PROGRAMMING:

1. This is the default operation after a factory reset.
2. Turn on optional "Creep Stop" for more realism so the trains creep to the STOP sensor.
3. Set an optional lap count if desired.
4. Set a longer acceleration rate if desired to creep out of the station.

## Station Stop with a Siding

After a few laps on the main line, go into the siding and stop.

== Parts List ==

- 1 StationMaster-6
- 1 YardMaster-5
- 2 Train sensors
- 1 magnet
- 1 three pin data cable

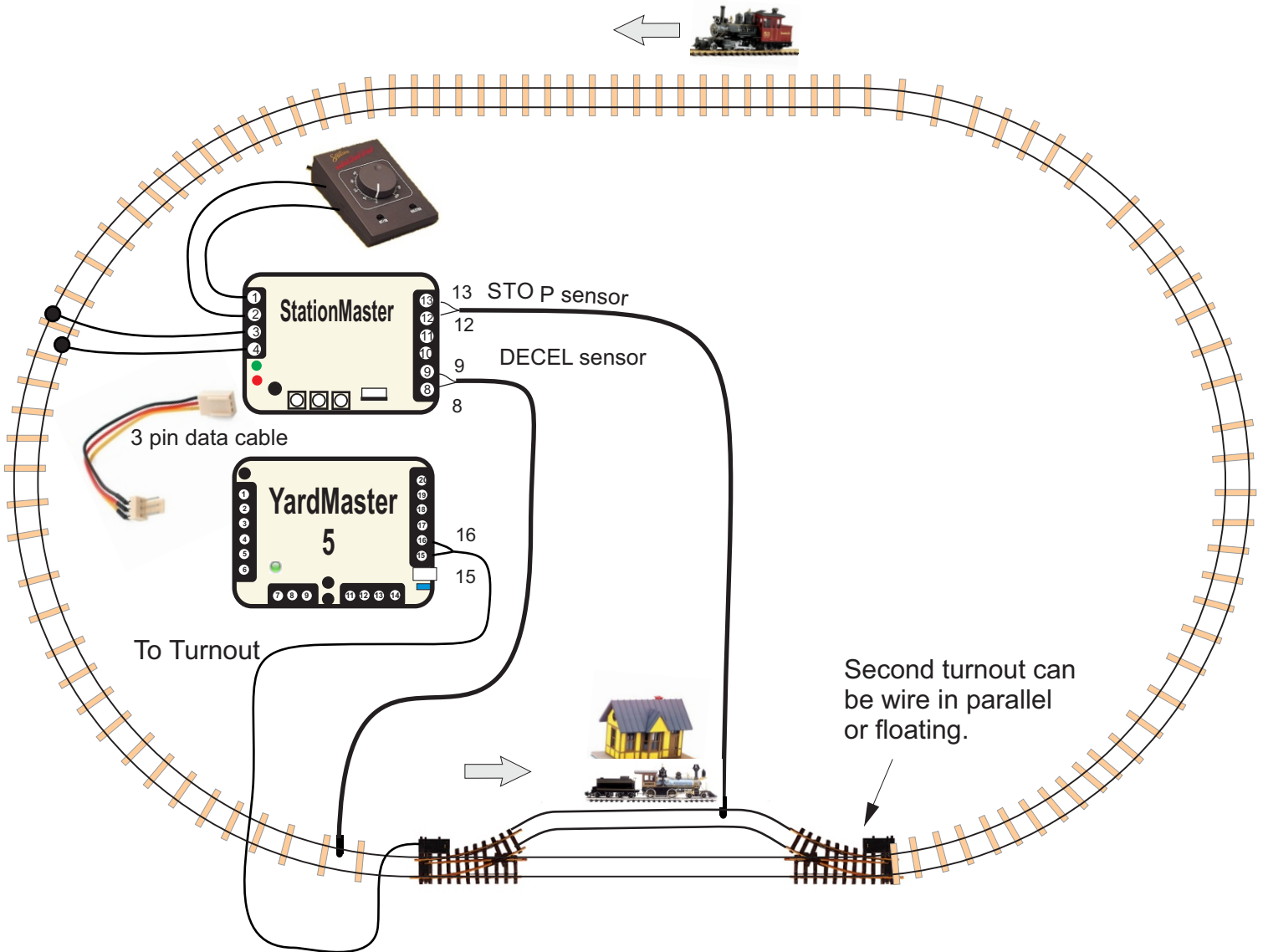

### OPERATIONS

- \* While counting laps, the YardMaster will fire to RED each time the DECEL sensor is ran over.
- \* After the lap counting has finished, the YardMaster will fire to GREEN on the DECEL sensor and the train will stop in the siding.

### PROGRAMMING:

1. Turn on blinks 1 and 2 in "features" programming. (2 is set by default after a factory reset)
2. Program a lap count greater than 1.
3. Turn on "Creep stop" in "features" programming OR set a deceleration rate such that the train reaches the STOP sensor.



## Programming: Stopped Voltage

When the train is stopped, a small voltage can be put on the track to maintain lights, smoke, or sound. This feature can be set from the tertiary (third) programming mode. Notice that a setting which is too high could cause the train to creep. Choose a setting which works for your train.

### HOW TO PROGRAM:

1. **Enter Tertiary Programming mode:** (Skip this step if already in tertiary programming mode)

- \* Turn the Top Speed dial fully counter-clockwise to enter programming mode  
The blue "Train Detected" LED will "twinkle"

- \* Turn the Top Speed dial slowly clockwise until the sensor LED turns Green and then **BLUE**.  
This indicates tertiary programming mode. (Only available on software after 2020)

- \* At this time the currently programmed stopped voltage will be put on the track.

2. **Press and hold button #1 to decrease the voltage, or button #2 to increase the voltage.**

Watch the train and choose a value that works.

***When finished do not power off without first turning the dial fully clockwise.***



## Automatic Shutdown Details

The StationMaster has advanced electronics and software which will attempt to protect itself and also your trains when potentially disastrous events occur.

Some transformers know their current capability and will shut down when a current threshold is reached but for sensitive electronics this is sometimes too late. The StationMaster determines what a short circuit is by causing a very brief short circuit after a factory reset, and then records the event. When that event happens again the StationMaster will shut down and blink the red and blue LEDs.

### HOW TO RESET THE SHUTDOWN THRESHOLD

The shutdown threshold is set after a factory reset. Make sure the train transformer is set to 100% when exiting programming mode. The Shuttle will short the track and then record the new value. If the train transformer was set to a low speed then a bad value would be recorded which could cause false shutdowns.

It is also possible to reset the shutdown threshold when the Shuttle is in the red flashing shutdown condition. When in the shutdown state, press and hold button #3 for 3 seconds. Make sure the transformer is at 100%. This allows resetting the shutdown without performing a full factory reset.

### SMALL TRANSFORMER OVERRIDE

For small transformers it may not be possible to obtain a shutdown value, since the transformer could be operating at 100%. In this case the shutdown blinking will occur frequently and the "No Shutdown" option must be programmed. "Small transformers" will be less than 2AMPS or 30VA. It is unlikely that the StationMaster would be stressed with a short circuit of only 2 AMPS or less, and the transformer would most likely shut down too. See the "No Shutdown" setting in Secondary Programming Mode for details on setting this.

## Electrical Details

For reference only

The locations of the common grounds could be useful for some wiring harnesses.

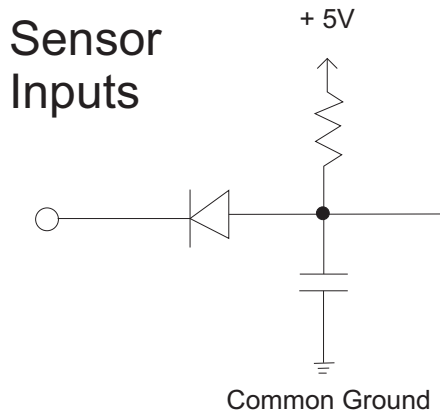
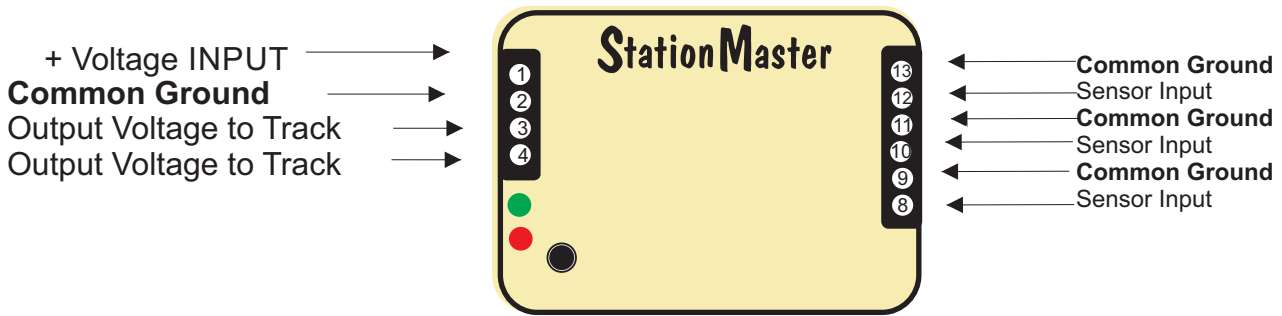

## Sensor Placements on Track

The suggested sensor placement on track is shown below with the train magnet installed in the center of the train. Best sensing is done with the magnet passing over the tip of the sensor.

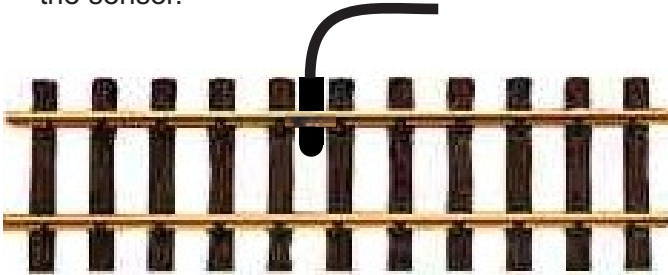

### Sensor Placement for identifying a train.

Offset the train's magnet to the same side as the sensor as shown.

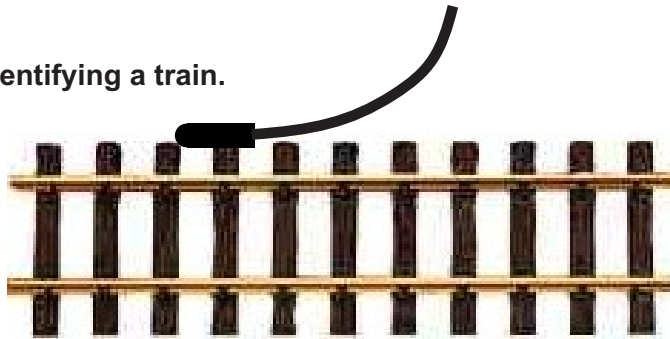

For example, passenger trains have the magnet offset to the right and freight trains have the magnet offset to the left side.

### Sensor placement for HO EZ track is under the roadbed.



Other scale trains can place the sensors where appropriate. Very small sensors are available which do not have the waterproof housing. These smaller sensors can be used for N, HO, etc. Contact RR Concepts for these sensors.

#### WARRANTY

Your StationMaster is warranted, and guaranteed operational for 1 year. It will be repaired or replaced at no charge within that time period. Contact <http://www.RR-Concepts.com> for additional information.