



# StationMaster - 5

## Train Controller - V2 software

This manual contains detailed hookup and programming instructions for the StationMaster train controller available in a 4 AMP or 10AMP configuration. The StationMaster-5 V2 has an upgraded current sensor, and upgraded software including creep-stop and creep-acceleration.

The StationMaster can control DC trains or DCC equipped trains set to linear mode.

**Before we Start-** Please do not attach power wires (from your power pack or transformer) to any other terminals except the designated input pins 1 and 2. Your StationMaster will be damaged if power is put on any of the sensor terminals.

### **ONLY ATTACH WIRES WHILE THE POWER IS OFF.**

Quick-connect terminals allow easy swap-out and removal of the electronics while leaving the wires in place. The RR Concepts Magnet/Screwdriver tool is recommended for wire-up and testing of operations.

See decal on bottom for optional programming information

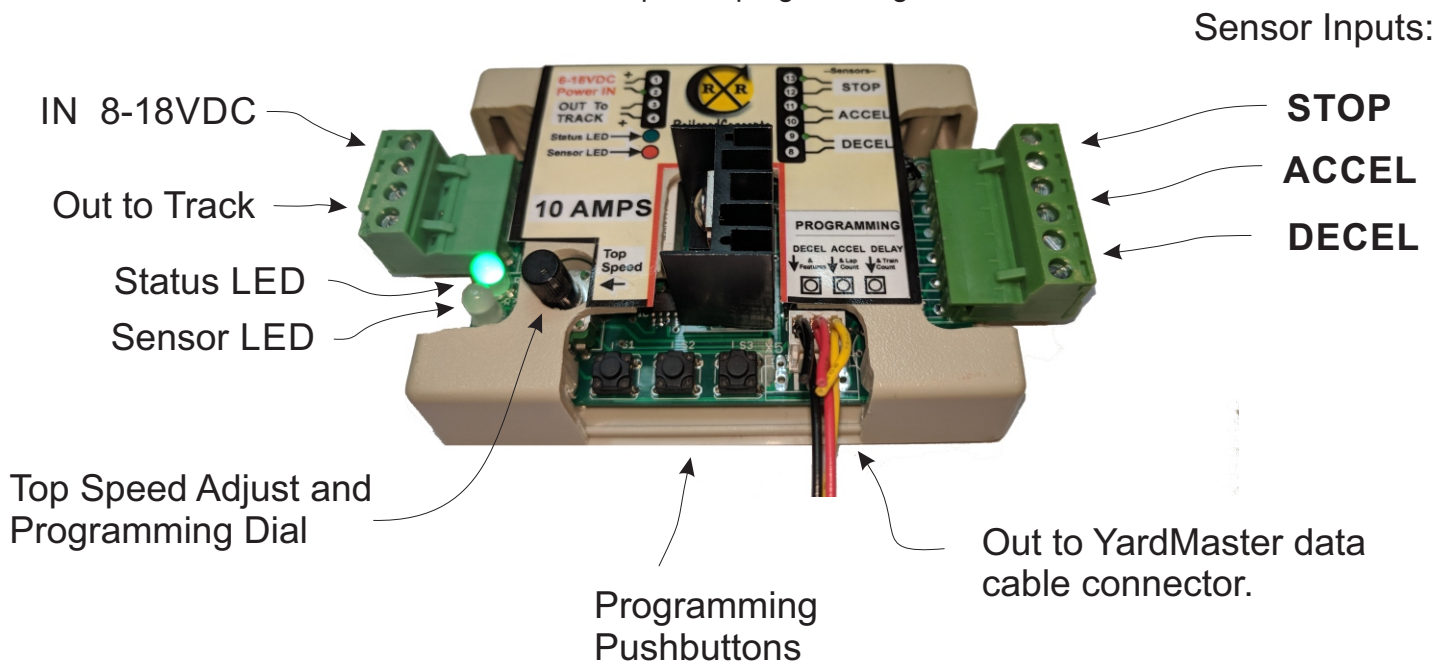

# RR Concepts StationMaster - 5

## Quick Hookup Instructions

How to do  
**Realistic Station Stops & Realistic Reversing** (More details in manual)

The StationMaster works with DC (out of the box) or DCC trains set to linear mode. (N, HO, G, etc.) AC trains cannot be controlled.

### StationMaster CONNECTIONS and CONTROLS

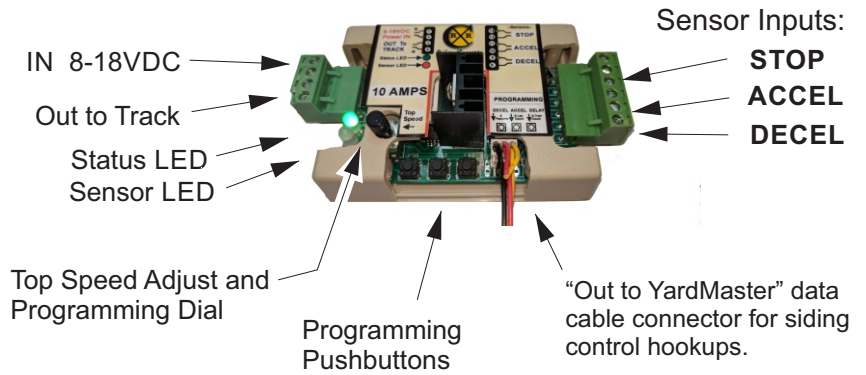

See the label on the bottom for programming and additional information.  
**10 AMP Version shown, Also available in 4 AMP configuration.**

### Station Stop Hookup

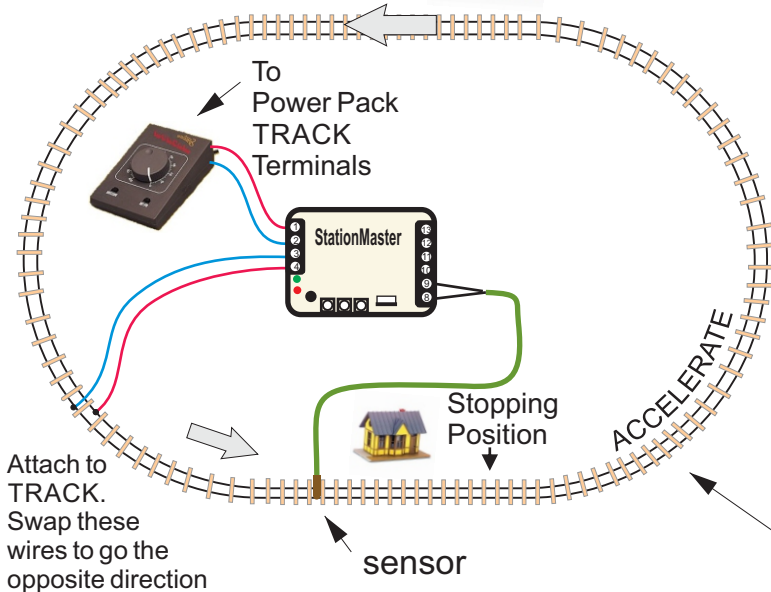

### Accelerate + Decelerate Station Stop Hookup

- 1) Attach terminals 1 & 2 to the transformer.
  - 2) Attach terminals 3 & 4 to the track.
  - 3) Attach terminals 8 & 9 to a train sensor. (No polarity)
  - 4) Mount a magnet on an engine or car.
- Set the transformer to the desired top speed. That's it!

See the online manual for optional additional features:

- \* Change acceleration rate,
- \* Change deceleration rate,
- \* Add additional station stops,
- \* Do multiple laps before stopping,
- \* Run 2 trains on the same track.
- \* Change station stop pause duration, (Default 10 seconds)
- \* Perform "Creep-Stop" deceleration for enhanced realism and exact stopping location. (Requires STOP sensor)

**Un-modified track!  
No diodes, no breaks, no additional track connections.**

### Reversing Hookup

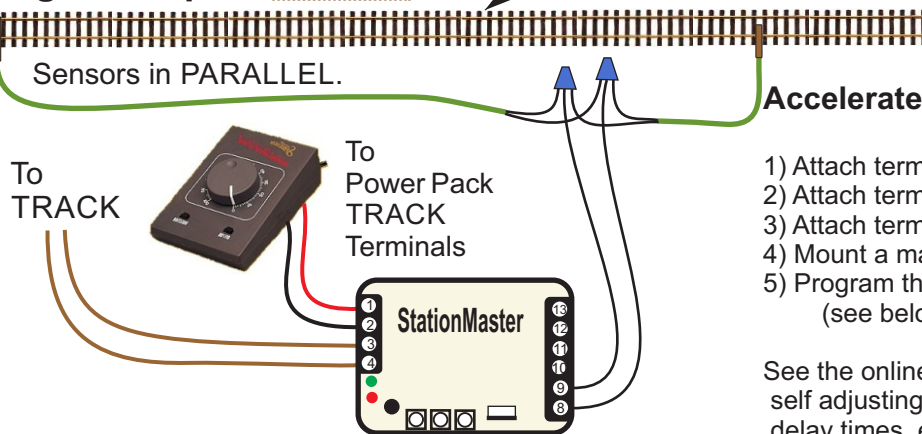

### Accelerate + Decelerate Reversing Hookup

- 1) Attach terminals 1 & 2 to the transformer.
- 2) Attach terminals 3 & 4 to the track.
- 3) Attach terminals 8 & 9 to train sensors near the ends.
- 4) Mount a magnet on the engine.
- 5) Program the StationMaster for "Blink 1" (see below for programming)

See the online manual for additional in-between stops, self adjusting exact stopping using STOP sensors, delay times, etc,

How to program "Blink 1" reversing mode:

1. Turn the top speed dial fully counter-clockwise.
2. Turn the top speed dial *slowly* clockwise until the GREEN LED comes on.
3. Press and hold button #1 for 1 blink and then release. (See the manual for more details)
4. Turn the top speed dial fully clockwise.

Go to **StationMaster.net** (bottom of page) and download the 25 page user manual for more info. Visit **RailroadConcepts.com** for more fun, advanced hookups, and ordering parts.





## StationMaster Basic Hookup Description

The StationMaster is designed to be installed between the train transformer, and the track.

Attach terminals 1 & 2 to your transformer's DC output (Sometimes labeled as TRACK) or to a constant 12 volt power source. If using a train transformer set the throttle position to the desired top speed of the train. If the StationMaster does not "light up", then reverse the direction on the transformer to change the voltage polarity, or swap these two wires.

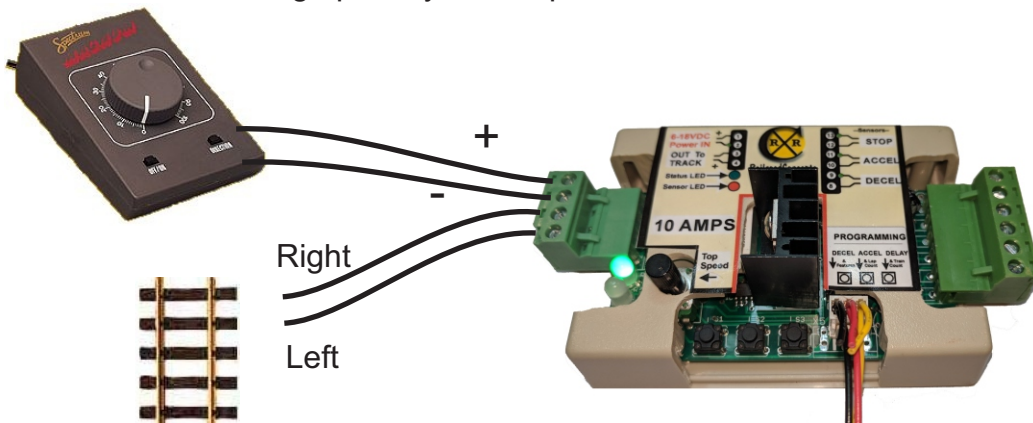

Attach 3 & 4 to your track. This is the controlled output voltage that accelerates and decelerates the train. Pin 3 will be the "common" wire which is the *right rail* for Large Scale trains or the *left rail* for NMRA standard trains.

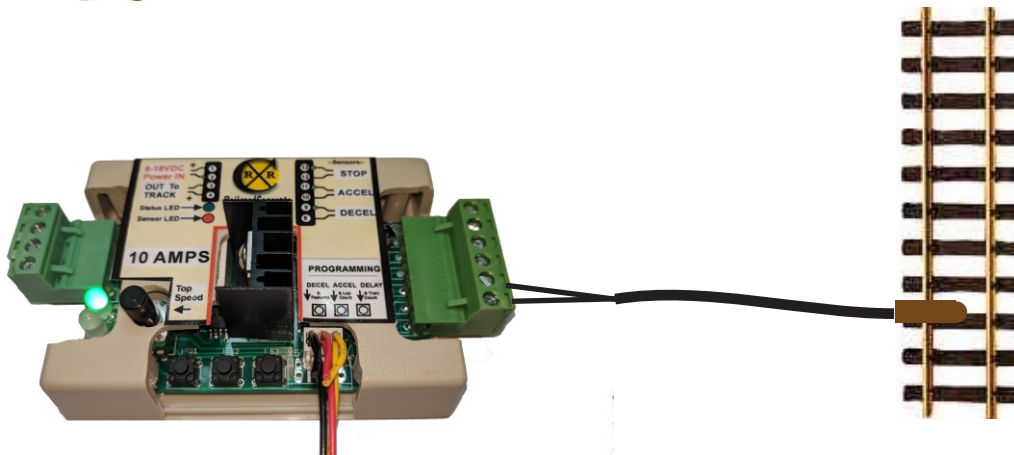

### DECEL Sensor

Terminals 8 & 9 are the start DECEL sensor input. When these terminals are closed (sensor detects a magnet) the StationMaster will begin a decelerate, pause, and then accelerate sequence. The RED "Sensor LED" will light up for as long as this sensor is detected. By placing multiple sensors wired in parallel, the StationMaster can stop at multiple stations on your railroad.



Pressing button #1 will simulate the DECEL sensor operation.



### ACCEL Sensor

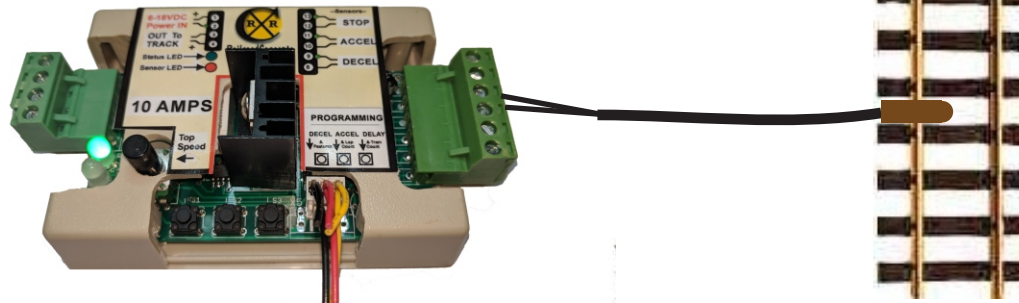

Terminals 10 and 11 are the *optional* **Start Acceleration** sensor inputs.

When these terminals are shorted (sensor detects a magnet) the train will start to accelerate.

This sensor is **not** necessary unless using “Block Control” or the **time delay** is set for maximum blinks. (See below).



Pressing button #2 will simulate the ACCEL sensor.

When programmed for “Blink1: Simple reversing mode” this sensor will perform an in-between station and the ACCEL function will not be operational.

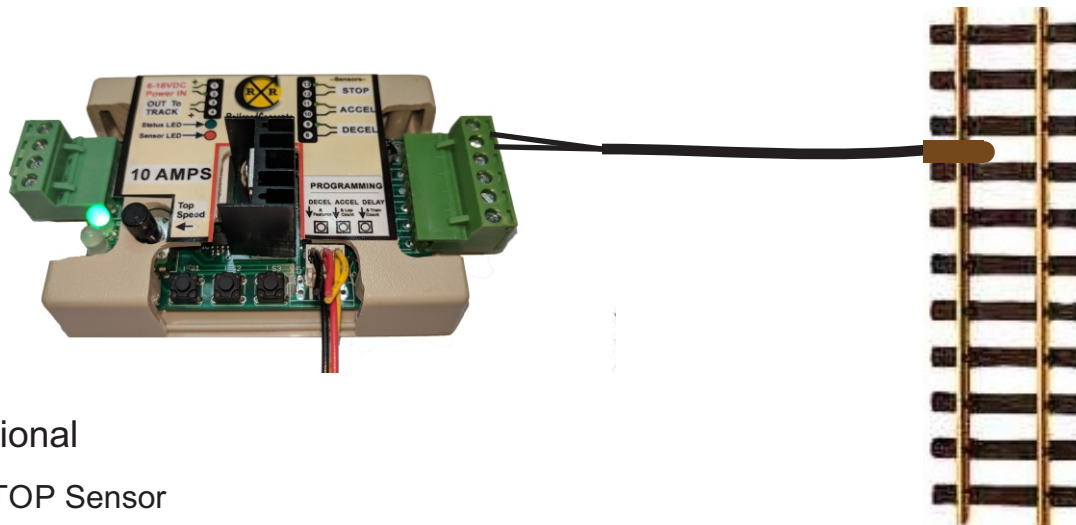

### Optional

#### STOP Sensor

Terminals 12 and 13 are the optional STOP sensor inputs.

**When the train is decelerating** and these terminals are shorted (sensor detects a magnet), the train will immediately STOP. This sensor is not necessary unless using the “Creep-stop” mode in which case it is mandatory.

The STOP sensor will have no affect unless the train has already passed over the DECEL sensor.



Pressing button #3 will simulate the STOP sensor.



## Top Speed and Programming Mode Dial

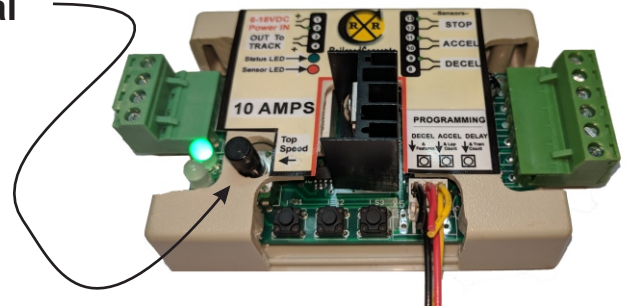

The Top Speed dial provides 2 functions:

- 1: Adjust the top "cruising" speed of the train.
- 2: Enter programming mode.

### Top speed adjustment

"Full speed" is clockwise. Turn this dial down as necessary to set the desired cruising speed of the train. This is only necessary when using a "fixed voltage" power supply or when a YardMaster is attached and a slower top speed is desired.

**Typically, this dial is set fully clockwise and the train throttle (transformer) is used to set the speed of the train.**

### Programming Mode

To enter programming mode turn this dial fully counter-clockwise. The Sensor LED will display orange to indicate "programming mode".

The acceleration rate, deceleration rate and time delay can be programmed in this state. See the programming details or decal on bottom of the StationMaster for additional information.

To exit programming mode turn the dial fully clockwise.

When exiting programming mode the following will automatically occur:

1. The shutdown current will be programmed. (Relays will briefly short the track and measure the amperage consumed)
2. All "creep-stop" values will reset.



# LED indicators

For Information only

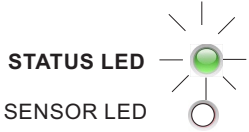
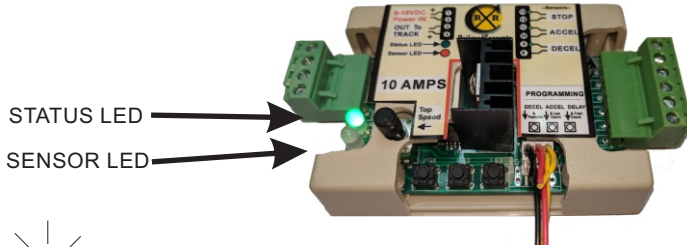

Green flashing: train is **ACCELERATING**.

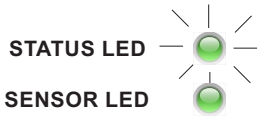

Green flashing with green solid: Train is creeping out of station. After a delay the train will continue to accelerate up to top speed.

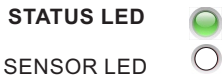

Green NOT flashing: Train is **AT TOP CRUISING SPEED**.

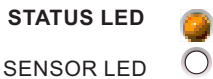

1. Orange NOT flashing, The StationMaster **will ignore next DECEL sensor** due to lap counting or block control.
2. Orange Flashing, The StationMaster is performing a time delay.

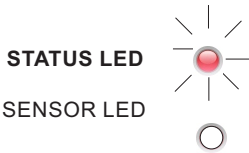

1. Quick Red flashing: Train is **DECELERATING**. Flash rate indicates the rate of deceleration.
2. Two quick RED flashes at 1 second rate: StationMaster is **waiting for the ACCEL sensor** before accelerating. (StationMaster is programmed for infinite time delay)

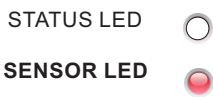

Sensor RED LED ON or flash: The STOP sensor is detected. The LED will remain on for as long as the sensor is detected. *If a train is parked on the STOP sensor then the deceleration sensor will be ignored.*

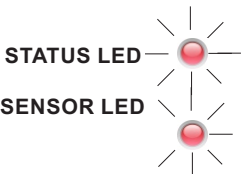

Two Red Blinking LED's indicate a **SHORT CIRCUIT** condition. Turn the top speed dial to zero and then back to 100%, Push button 3, or turn off power to recover. If condition returns after recovery check for a short circuit on the track or re-program the shutdown threshold. (Set throttle to full speed, enter and exit programming mode, then set throttle to running speed)

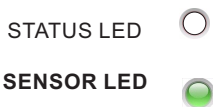

Sensor LED solid GREEN indicates secondary Programming mode.

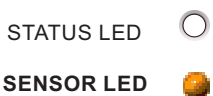

Sensor LED orange flickering: Indicates programming mode. The top speed dial is full counter-clockwise.



RRConcepts.com

## Programming: Deceleration Rate

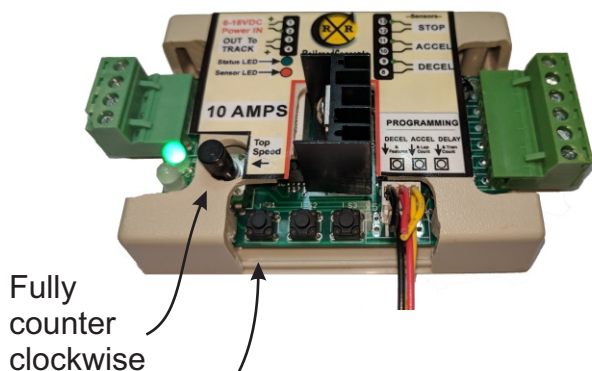

Fully  
counter  
clockwise

1. Make sure all three sensor inputs are open. (Red LED is off)
2. If the top speed dial is not already at zero, then turn the top speed dial to zero. (fully counter-clockwise.) Sensor LED will be orange..
3. Push and hold programming button #1.
4. Watch the status led. Each RED blink will increase the deceleration distance. The fastest deceleration will be with one blink. (TRAIN Stops sooner) Release the pushbutton when the desired number of blinks have occurred. A typical number is 5. Repeat this procedure if you want a different value. The LED will flash orange when the longest Deceleration rate is set.



When finished with all programming turn the top speed dial fully clockwise and then turn down to a desired top speed if needed.

All programming values are stored in flash memory and are retained until re-programmed.



RRConcepts.com

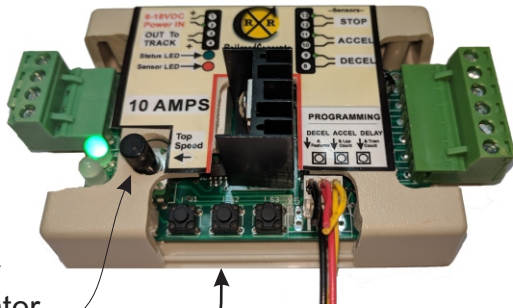

Fully  
counter  
clockwise

## Programming: Acceleration Rate

1. Make sure all three sensor inputs are open. (Red LED is off)
2. If the top speed dial is not already at zero, then turn the top speed dial to zero. (fully counter-clockwise.) All LED'S will turn off.
3. Press and hold programming button #2..
4. Watch the status led. Each GREEN flash will decrease the acceleration rate. The fastest acceleration will be with one blink. Release the button when the desired number of blinks have occurred. A typical number is 5. Repeat this procedure if you want a different value. The LED will blink orange when the longest **acceleration** rate is set.



When finished with all programming, increase the top speed dial clockwise to MAX and then down to a desired top speed. All programming values are stored in flash memory and are retained until re-programmed.

### Programming Realistic Accelerations:

- \* For blinks 1 thru 9 the train will accelerate with the programmed value.
- \* For blinks 10 and above the train will creep very slowly out of the station for 15 seconds and then gradually increase the acceleration rate as it continues. This provides a very realistic operation and shows off train sound systems with incredible realism.

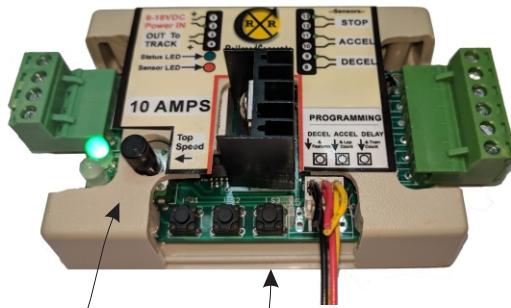

## Programming: Pause Time

Fully  
counter  
clockwise

1. Make sure all three sensor inputs are open. (red Led is off)
2. If the top speed dial is not already at zero, then turn the top speed dial to zero. (fully counter-clockwise.) All LED'S will turn off.
3. Press and hold programming button #3.
4. Each ORANGE flash will increase the waiting time after a station stop. A wait time of zero will be with one flash. Release the button when the desired number of flashes have occurred. Repeat this procedure if you want a different value.

The LED will turn orange when an infinite delay is set (after 10 counts).

**When infinite delay is set, then the ACCEL sensor is required to start up the train after a station stop.** A fun thing to do would be to connect the ACCEL terminals to a doorbell switch. Your train would patiently wait until someone pushed the button! Motion sensors are another possible way to start the train.



When finished with all programming increase the top speed dial clockwise to maximum or to a desired top speed. All programming values are stored in flash memory and are retained until re-programmed.

The number of orange FLASHES will correspond to the following time delays:

- 1: 0 seconds, no wait.
- 2: 5 seconds,
- 3: 10 seconds,
- 4: 30 seconds,
- 5: 1 minute,
- 6: 2 minutes,
- 7: 5 minutes,
- 8: 10 minutes,
- 9: 30 minutes,
- 10: Infinite, wait for GO sensor. This is for block control operations.

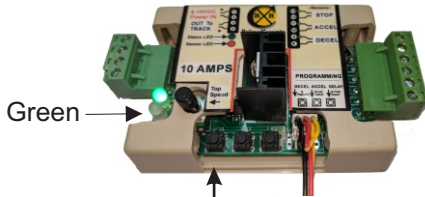

Please go to [RRconcepts.com](http://RRconcepts.com) to view an informational video on how to program operating modes.

## Programming: Operating Modes

**HOW TO PROGRAM:** (Perform a factory reset to clear everything)

**1. Enter Secondary Programming mode:** (Skip this step if already in secondary programming mode)

- \* Turn the Top Speed dial fully counter-clockwise to enter programming mode (Skip this step if already in programming mode).
- \* Turn the Top Speed dial slowly clockwise until the sensor LED turns green. This indicates secondary programming mode. This should be about half-way.

**2. Press and hold programming button #1** until the desired number of blinks have occurred. Each blink will set or clear a different feature. If currently ON it will turn off. If OFF it will turn ON.

**When finished do not power off without first turning the dial fully clockwise.**



**Programmable Modes:** (Any or all of these or all can be programmed independently)

- Hold button for 1 blink = Simple Reversing Mode, ignore next sensor after reversing, ACCEL sensor will perform an in-between station stop.
- Hold button for 2 blinks = Fire YardMaster after train has stopped. (Default ON after a factory reset)
- Hold button for 3 blinks = Fire YardMaster before acceleration. (Used for passing sidings)
- Hold button for 4 blinks = Use automatic train detection to start deceleration. (No-sensor station stops)
- Hold button for 5 blinks = Reverse direction before every acceleration. Never ignore sensors.
- Hold button for 6 blinks = Only fire YardMaster in forward direction. (For reversing operations with a siding on one end)
- Hold button for 7 blinks = Shut off current sensor. This could cause damage to the StationMaster unless the transformer can provide short-circuit shutdown. This is sometimes necessary when running with very small transformers. (1 AMP or less)
- Hold button for 8 blinks = Turn on "creep stop". The train will decelerate then creep until reaching the STOP sensor. LEDs will flash RED/GREEN when creeping.

When the button is released the StationMaster will echo the currently programmed features (modes) by blinking the red/green LED 8 times. *For example*, if "Fire YardMaster after train has stopped" has been programmed (button pressed for 2 blinks) and nothing else is programmed then the StationMaster will blink:

- blink 1 RED: Reversing mode is OFF.
- blink 2 GREEN: Fire YardMaster after stopping ON
- blink 3 RED: Fire YardMaster before acceleration OFF
- blink 4 RED: Use train sensor to start deceleration OFF
- blink 5 RED: Reverse direction before every acceleration OFF
- blink 6 RED: Only fire YardMaster in forward direction OFF
- blink 7 RED: Disable current sensor: OFF
- blink 8 RED: Creep-stop mode : OFF

Each time a feature is programmed that feature will toggle on or off. (Toggle means the feature will go OFF if currently ON, or ON if currently OFF). A factory reset will clear all values and set bit 2.

**To view the currently programmed operating modes quickly press and release button #1.**



Additional Information on Programming Modes. The hookup diagrams will identify which of these need to be set.

blink 1 = Simple Reversing Mode

This will allow reversing operations with a DECEL sensor placed at the ends wired in parallel. After reversing the very next DECEL sensor will be ignored. In-between station stops can be done by adding sensors in parallel to the ACCEL terminals. The train will stop at every location where a sensor is placed. the ACCEL sensor operation will not be operational.

blink 2 = Fire the YardMaster after the train has stopped.

If programmed for more than 1 train the YardMaster will fire to the next siding after the train has stopped. Note that the StationMaster will automatically set this blink after a factory reset.

blink 3 = Fire YardMaster before acceleration.

If programmed for more than 1 train the YardMaster will fire to the next siding before accelerating This is used for passing sidings where a train will stop and allow a train to pass by on the other siding.

blink 4 = Use automatic train detection to start deceleration.

When a train is sensed entering the track section the StationMaster will start a deceleration sequence.

blink 5 = Reverse direction before every acceleration

This is similar to blink 1 however the StationMaster will not ignore any sensors and the ACCEL sensor will be operational.

blink 6 = Only fire YardMaster in forward direction. (only active in reversing mode)

This will allow a reversing operation with sidings on one end.

blink 7 = Disable current sense shutdown.

If a double RED blinking shutdown condition occurs too often then the power supply may be too small to provide sufficient current and is not reliably sensed by the StationMaster. The shutdown can be disabled however damage could occur if the transformer does not have short-circuit protection.

blink 8 = Turn on "CREEP STOP" mode.

The train will decelerate using the programmed deceleration rate, then creep until reaching the STOP sensor. If the STOP sensor is not reached within 25 seconds then the creep speed is increased.



RRConcepts.com

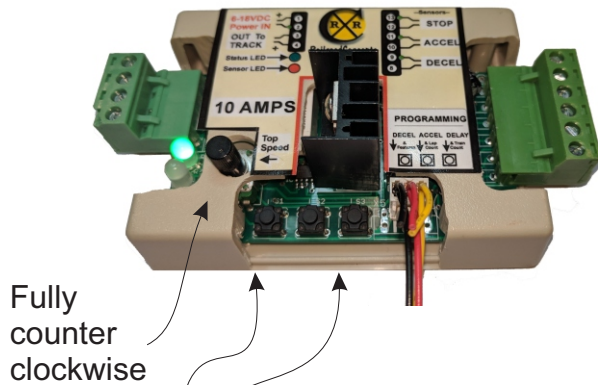

Fully counter clockwise

## Programming: Factory Reset

To set the StationMaster back to factory defaults perform the following:

- 1: Enter programming mode by turning the top speed dial fully counter-clockwise
2. Press and hold both button #1 and button #3, then release.
3. Save the settings by turning the top speed dial fully clockwise to exit programming mode.

**Do not power off without first turning the dial fully clockwise.**



The factory default settings are:

- \* Acceleration rate 5 blinks
- \* Deceleration rate 3 blinks.
- \* Time delay 5 seconds.
- \* Train count: 2 (Note: Block control will not be operation until set for 1 train)
- \* Lap count: 1
- \* Operating mode (features):

Blink 1 = RED, Simple Reversing: OFF.

Blink 2 = GREEN, Fire YardMaster before accelerating: ON

Blink 3 = RED, Fire YardMaster before decelerating: OFF

Blink 4 = RED, Use train sense to start deceleration: OFF

Blink 5 = RED, Reverse before every acceleration: OFF

Blink 6 = RED, Fire YardMaster only in forward direction: OFF

Blink 7 = RED, Disable current sensor: OFF

Blink 8 = RED, Enable CREEP-STOP mode: OFF



RRConcepts.com

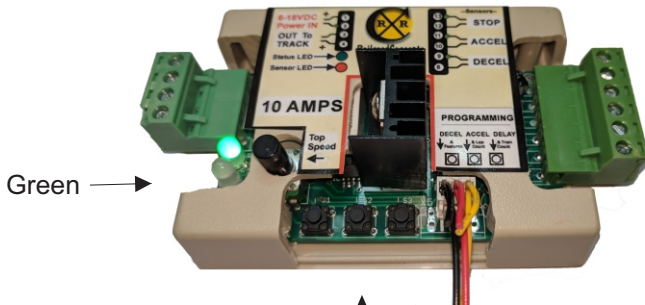

## Programming: MULTIPLE LAPS

:

1. Turn the Top Speed dial fully counter-clockwise to enter programming mode (Skip this step if already in programming mode).
2. Slowly turn the Top Speed dial clockwise until the GREEN indicator turns on. This indicates secondary programming mode. (Skip this step if already in secondary programming mode)
3. Press and hold button #2.
4. Count the blinks while the button is pressed. Release the button when the appropriate number of blinks (LAPS) are set.



When finished with all programming turn the top speed dial clockwise to maximum.

All programming values are stored in flash memory and saved until re-programmed again.



RRConcepts.com

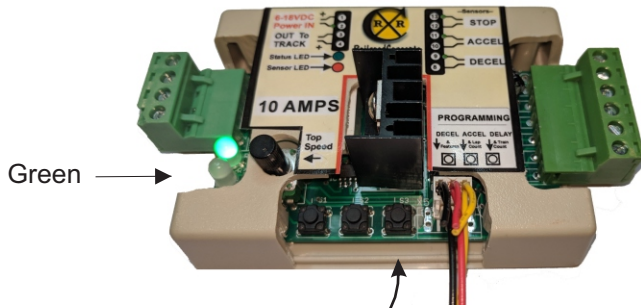

## Programming: Train Count

The train count is needed for 3 reasons:

1. Save different creep speeds for up to 5 trains.
2. Send signals to one or more YardMasters to correctly fire turnouts.
3. Allow running in a block-control mode. (Must be set for 1 train)

For example, a 3 track siding using 2 YardMasters attached to a StationMaster would have a train count of 3, since 3 trains will be controlled.

For an alternating siding hookup no programming is necessary since the default train count is 2.

## Programming:

1. Make sure all three sensor inputs are open.
2. If not already in programming mode turn the top speed dial to zero. (fully counter-clockwise.)
3. Slowly turn the top speed dial clockwise until the sensor LED turns GREEN. This indicates secondary programming mode. (Skip this step if already in secondary programming mode)
4. Press and hold button #3.
5. Each orange flash counts the number of running trains.

Release the button when the desired number of flashes have occurred. The number will be echoed back when the button is released.. Repeat this procedure if you want a different value.



When finished with all programming, increase the top speed dial clockwise to MAX, and then down to a desired top speed if necessary. All programming values are stored in flash memory and saved until re-programmed again.

**NOTICE: A factory reset will set the train count to 2.** Block control will not be operational until set for 1 train.

## “Justa Station Stop”

Justa-Station-stop performs a decelerate/Pause/Accelerate sequence without triggering an attached YardMaster or reversing.

When operating in an alternating trains setup additional stations stops can be done at different locations around the loop without affecting the parked train.

Place a STOP and a DECEL sensor such that they are both triggered at the same time. The train will decelerate, pause and accelerate without triggering a YardMaster and without changing directions.

If self-adjusting mode is programmed then the deceleration rate will be fixed. Otherwise the programmed deceleration rate will be used.

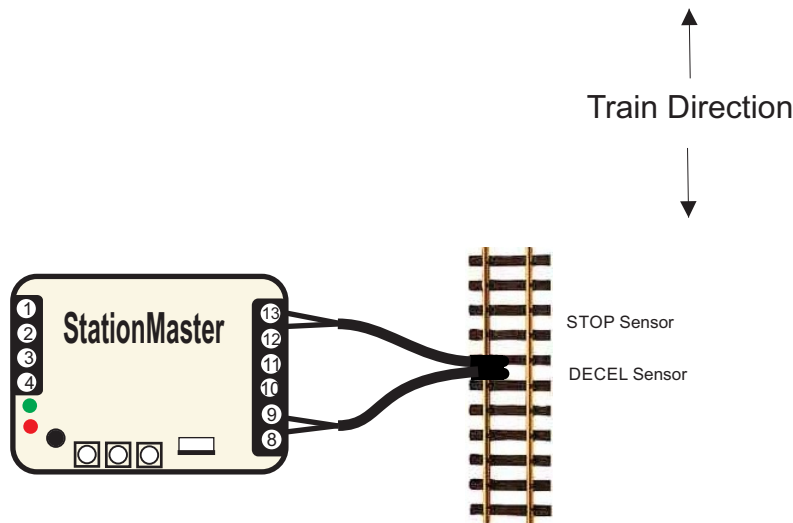

# Basic Hookup Diagram for Automatic Station Stops with Deceleration/Acceleration using train sensors.

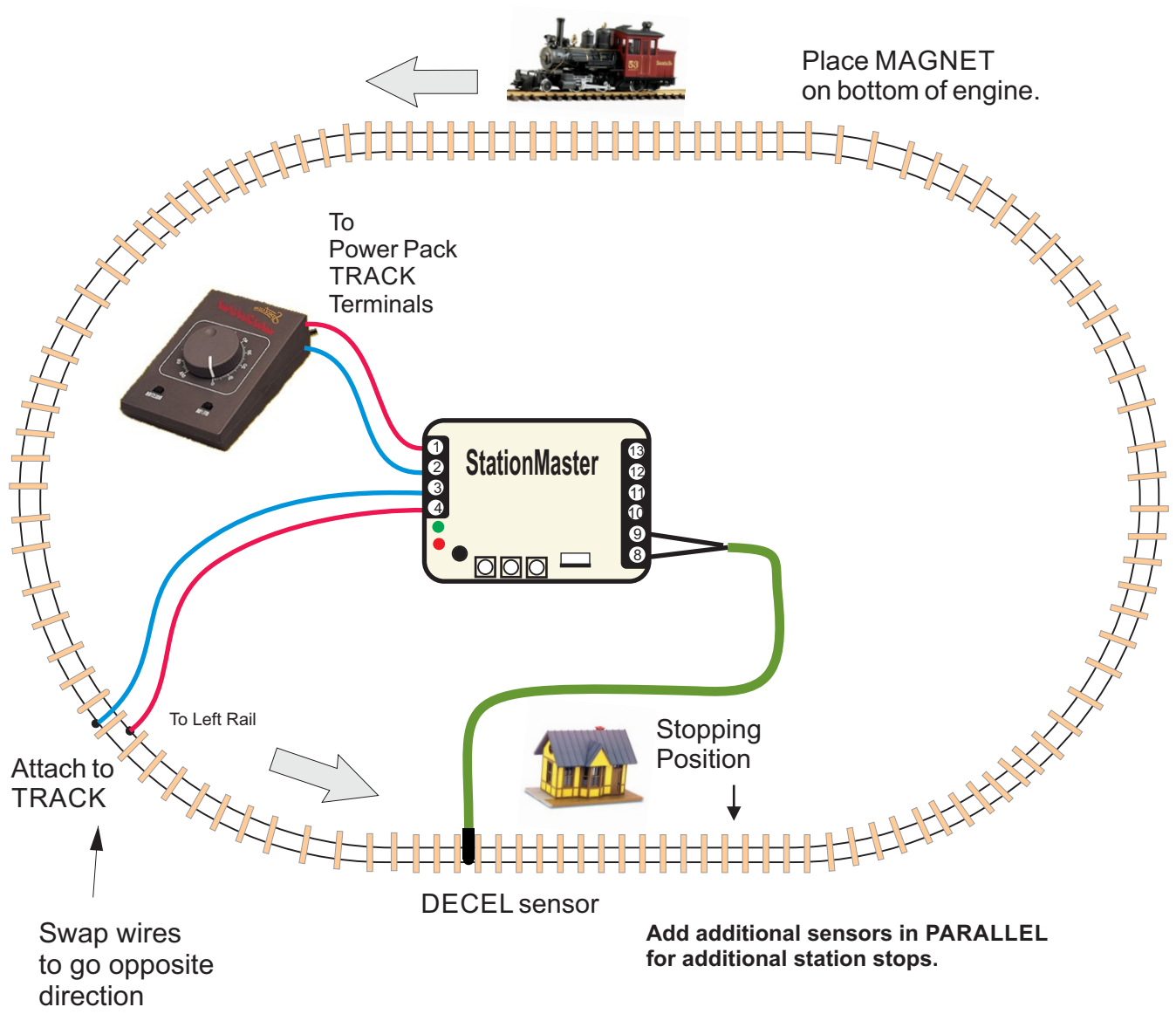

For a simple station stop, this is all you need to do!  
 Factory settings will be a gradual acceleration, gradual deceleration and 10 second stop.

### Multiple Station Stops

Your train can stop at many stations on the loop by adding DECEL sensors in parallel.

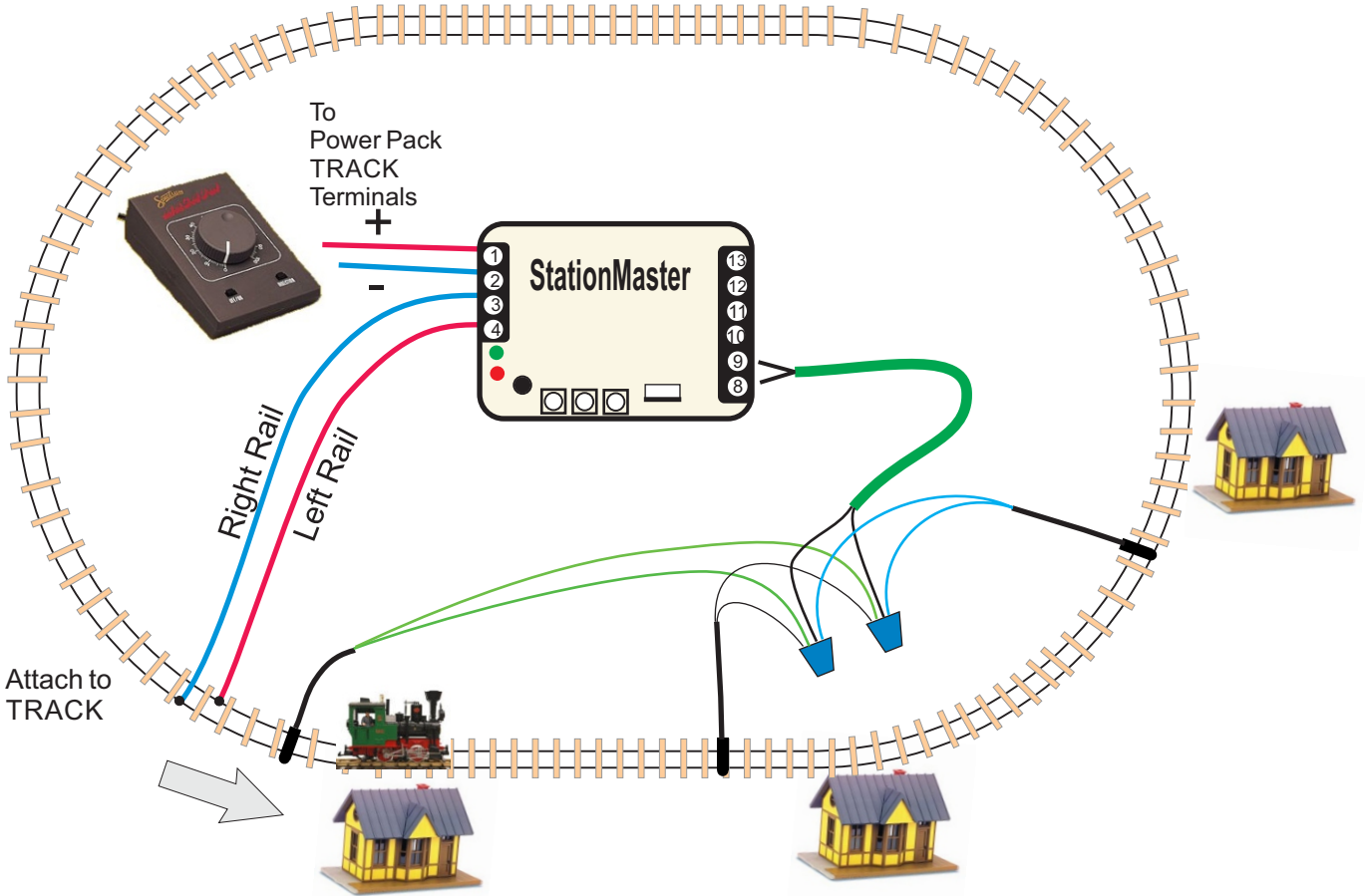

Every sensor that the train passes over will cause a decelerate/pause/accelerate sequence.



## Block Control

For 1 or 2 Trains on 1 track with gradual Decelerations and Accelerations.  
Can be located at a remote location on the railroad

Programming:  
\* Train count: 1  
\* Time delay: maximum

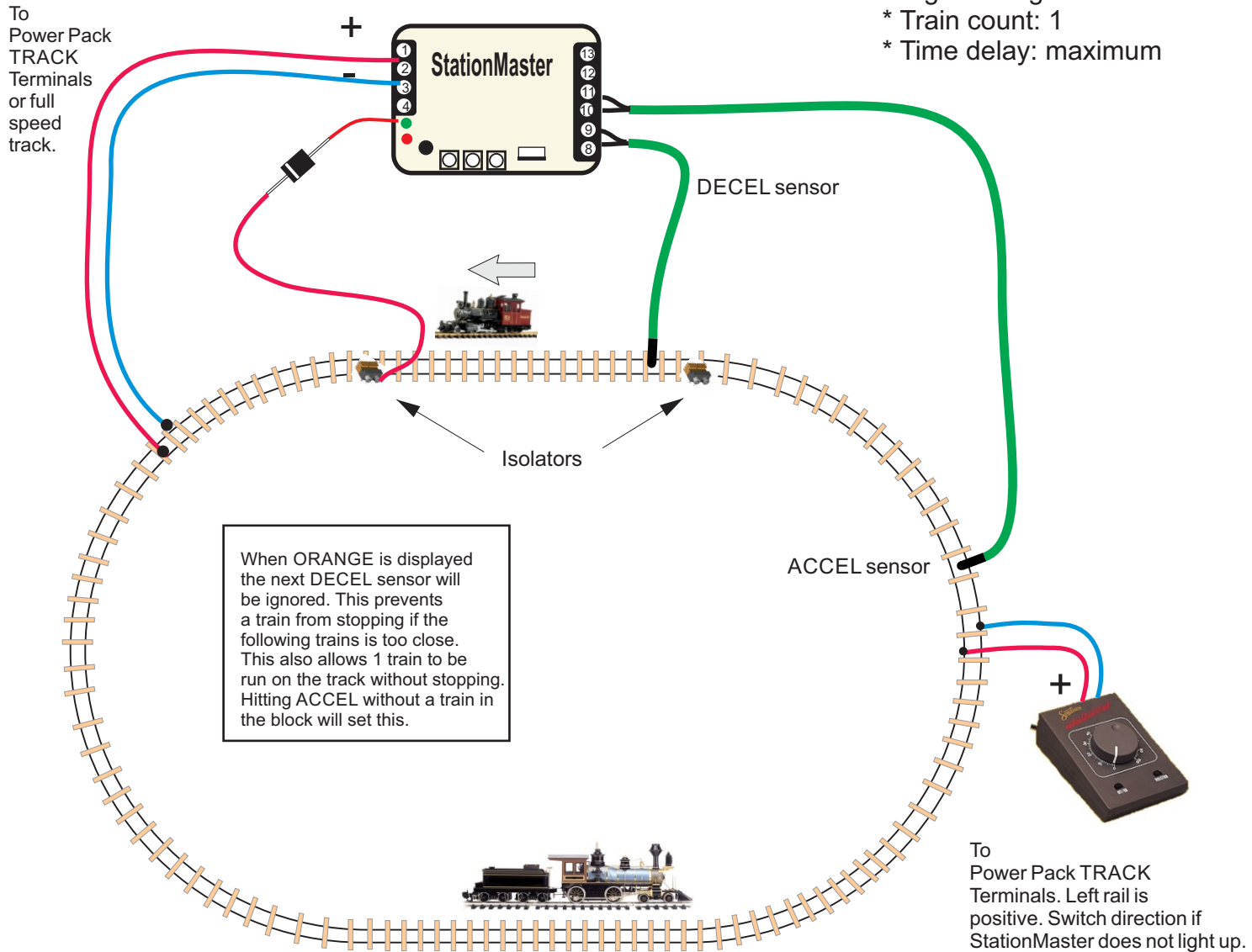

### Hookup Notes:

1. Your train may not stop if the second train is too close. (ACCEL is hit before DECEL)
2. When the train decelerates it must stop before reaching the 2nd isolator..
3. If the train is slowing or stopped, then the second train will tell it to "go" when it hits the ACCEL sensor. (Start with sensor half-way around the track. Station stop will be longer with ACCEL sensor closer.) Move the location of this sensor to fit your track.
5. Location of ACCEL sensor must allow the stopped train time to accelerate and exit before the 2nd train enters the siding.
6. This hookup can run with 1 train or 2 trains. (1 train will never stop unless ACCEL sensor is removed)
7. A longer isolated section will provide more realism for the stopped train to decelerate and accelerate.
8. Station can be located at a remote location on your railroad.



# Station Stop Without using Magnets or Sensors

Using the Automatic Train Detection feature.

Programming:  
\* Operational mode: blink 4

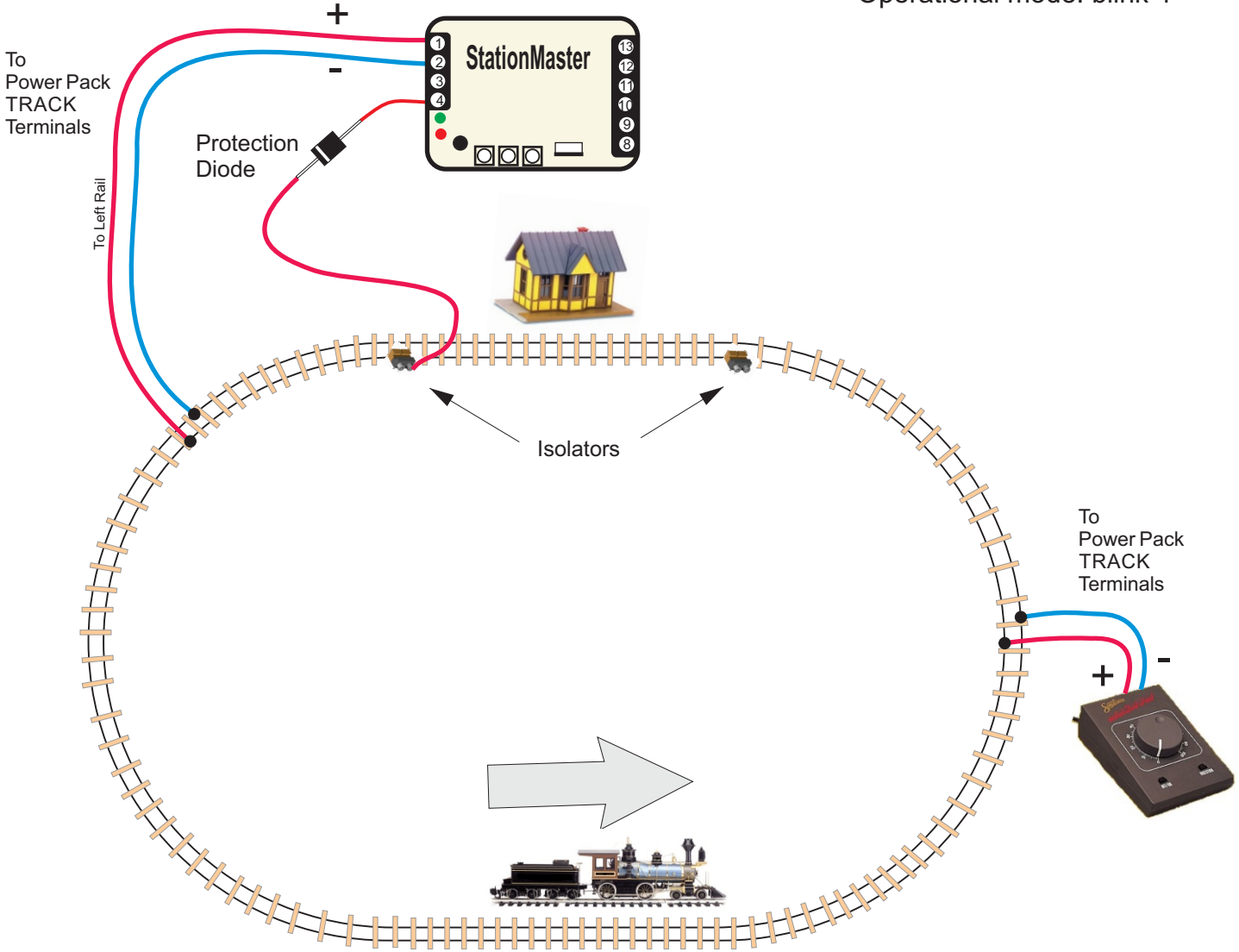

**Hookup Notes:**

1. Isolated section must be long enough to allow train to decelerate and accelerate.
2. Train can only go in one direction.
3. Protection diode prevents damage in case of train running backwards.
4. Program StationMaster for "blink 4".
5. Program time delay as desired.
6. No magnets and no sensors are required
7. Station stop can be located at a remote location on your railroad far from the transformer.



## “Creep-Stop” Deceleration for Incredible Realism

A unique and extremely realistic feature of the StationMaster is “Creep-Stop” Deceleration. By using both a DECEL sensor and a STOP sensor the StationMaster will provide a very realistic station stop. Programming your StationMaster to use “Creep-Stop” is very easy:

1. Set bit 8 in programming mode.(Press and hold button #1 in SECONDARY Programming mode until the LED blinks rapidly)
2. Place the **DECEL** and **STOP** sensors on your track as shown. The distance between sensors should be about 2 to 6 feet, or whatever looks good to you.
3. Program the deceleration rate (if needed) to provide a realistic deceleration into the train yard before the creep starts.

**That's it!**

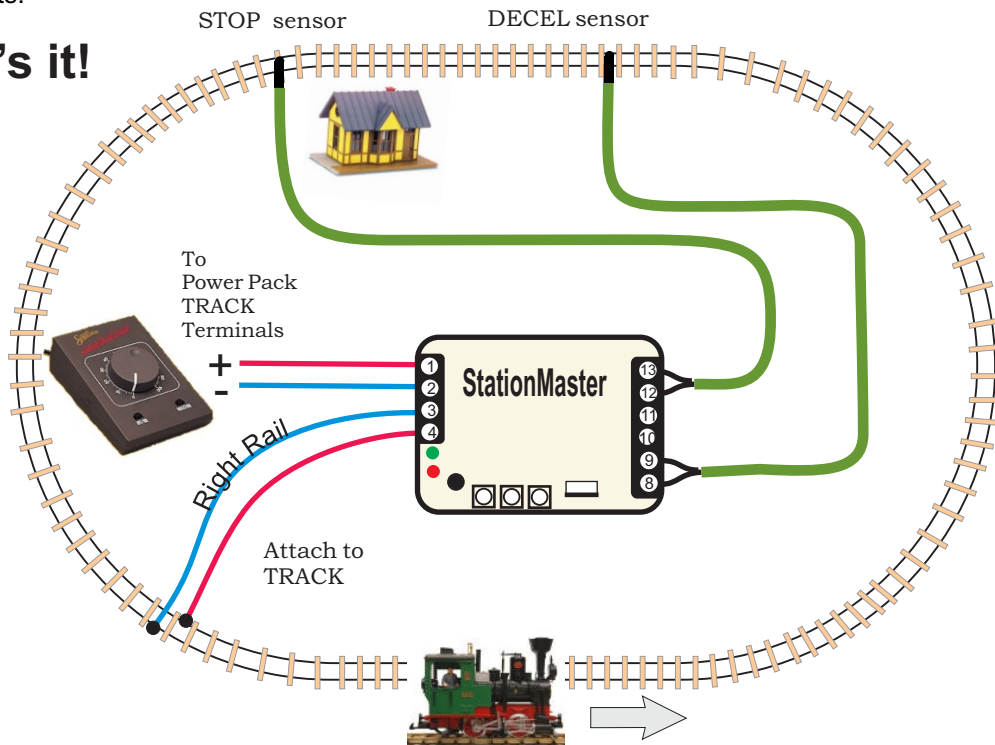

When “Creep Stop” is enabled, the train will decelerate using the programmed deceleration rate, then “creep” forward until the STOP sensor is reached. This guarantees the train will always stop on the STOP sensor using a realistic profile. The starting creep speed is relatively slow however the train must reach the STOP sensor within 25 seconds. If the train stalls, then the creep speed is increased for the next time.

The length of the creeping can be adjusted by either increasing or decreasing the distance between DECEL and STOP sensors, increasing or decreasing the deceleration rate, or both. Start with a 4 foot distance and see how that looks.

Up to 5 different creep speeds can be used for 5 different trains. Slow trains can run next to fast trains and each will creep perfectly, Use the “train count” to set the number of trains that will be run. A factory default will set for 2 trains which is perfect for an alternating siding setup.



RRConcepts.com

## Extremely Realistic Reversing Operations

When programming Mode **blink 1** is set the StationMaster will go into reversing mode.

Sensors are placed near the ends to signal the StationMaster to begin the deceleration / pause / accelerate operation. Sensors on the ends stop the train at an exact location. Sensors have no polarity. Place sensors about 2 feet apart for realistic operation. Set the StationMaster for "Creep-Stop" mode, and program the acceleration and deceleration as desired.

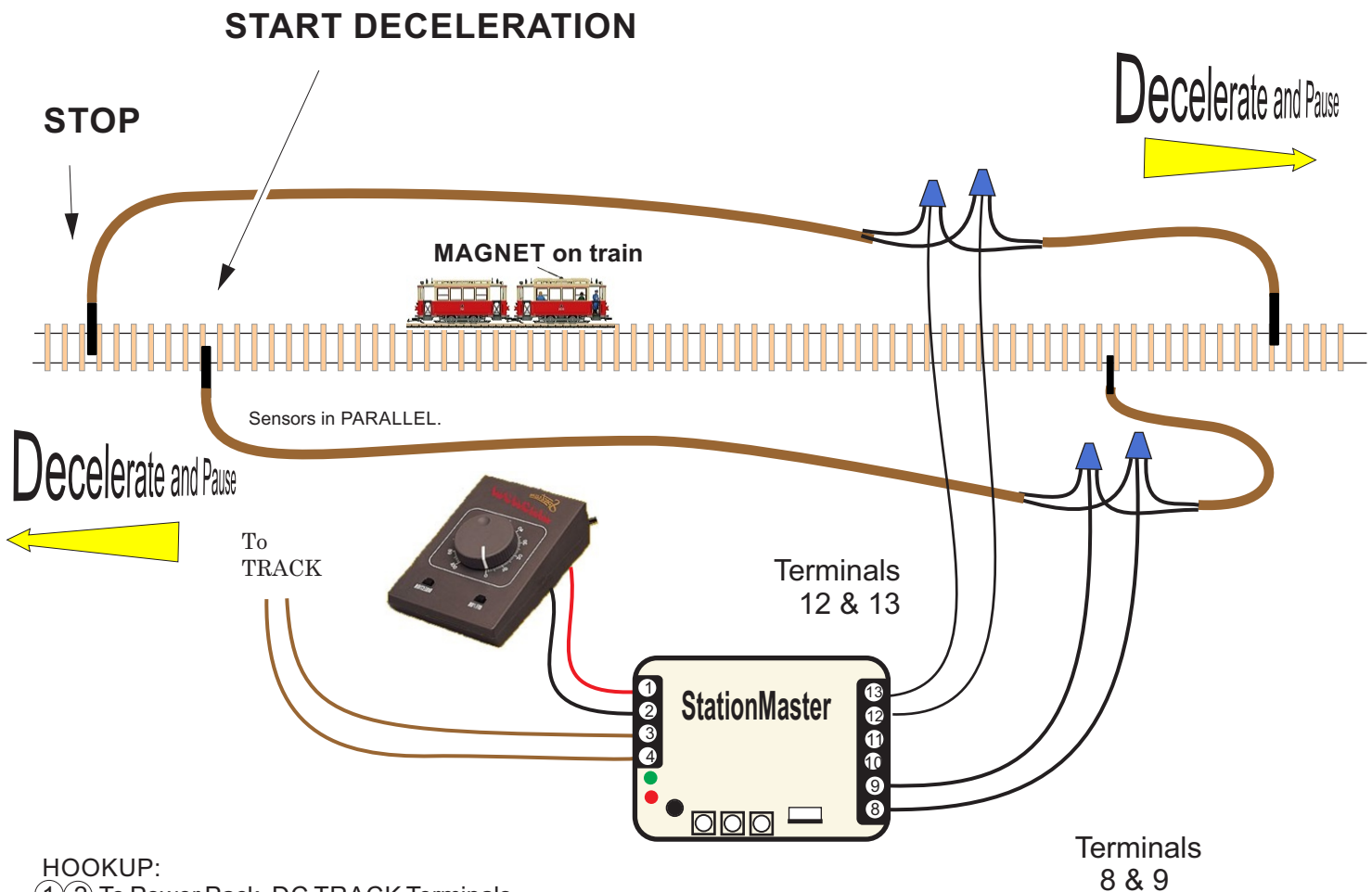

### HOOKUP:

- ①② To Power Pack DC TRACK Terminals.  
If StationMaster does not turn on then reverse direction on the transformer.
- ③④ To Track
- ⑧⑨ To DECEL sensors wired in parallel.
- ⑫⑬ To STOP sensors wired in parallel.



See next page for optional in-between station stops.

## Extremely Realistic Reversing Operations with In-Between stops

(See the previous page for wiring the reversing operation)

When running in a back-and-forth reversing operation In-Between station stops are done by placing pairs of ACCEL sensors on the track. When the StationMaster detects an ACCEL sensor it will perform a “Justa-Station-Stop operation”. The ACCEL sensor input will not perform an acceleration operation when programmed for simple reversing mode (Blink 1)

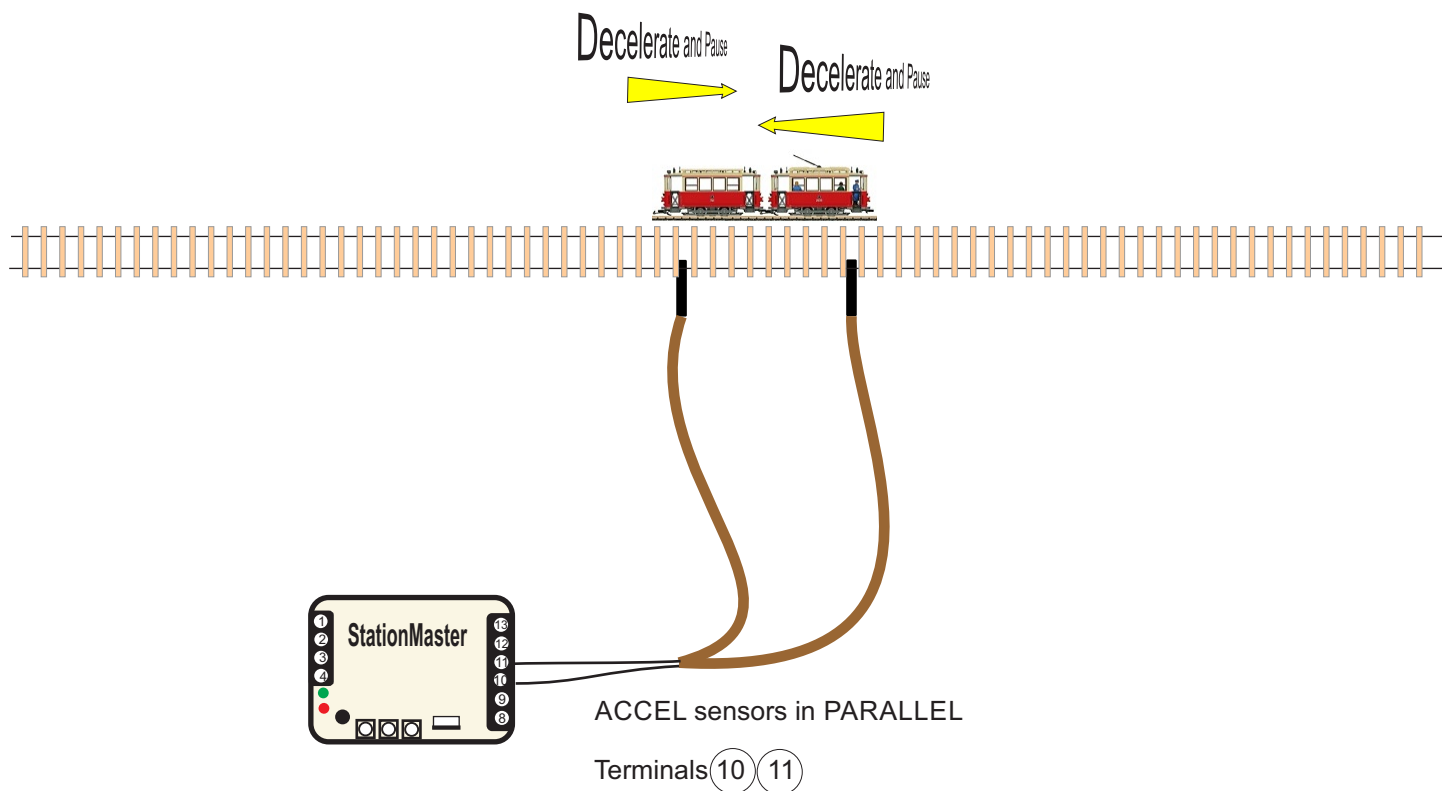

### NOTES:

1. The train magnet must stop between the pair of sensors. This will allow the train to stop at the same location from either direction. When the train accelerates it will ignore the very next sensor that it passes over so it must stop before reaching the 2nd sensor. One sensor *can* be used for a single in-between stop however the train will stop at a different location for each direction. (It will decelerate and stop after passing over the sensor)
2. Sensors have no polarity.
3. Additional station stops can be done by adding additional pairs of sensors, all wired in parallel. There is no limit to the number of stops that can be done..

**Alternate 2 Trains at a Siding,  
Trains Travel Opposite Directions,  
SPRING-RETURN  
TURNOUTS**

**TRACK CONNECTIONS**

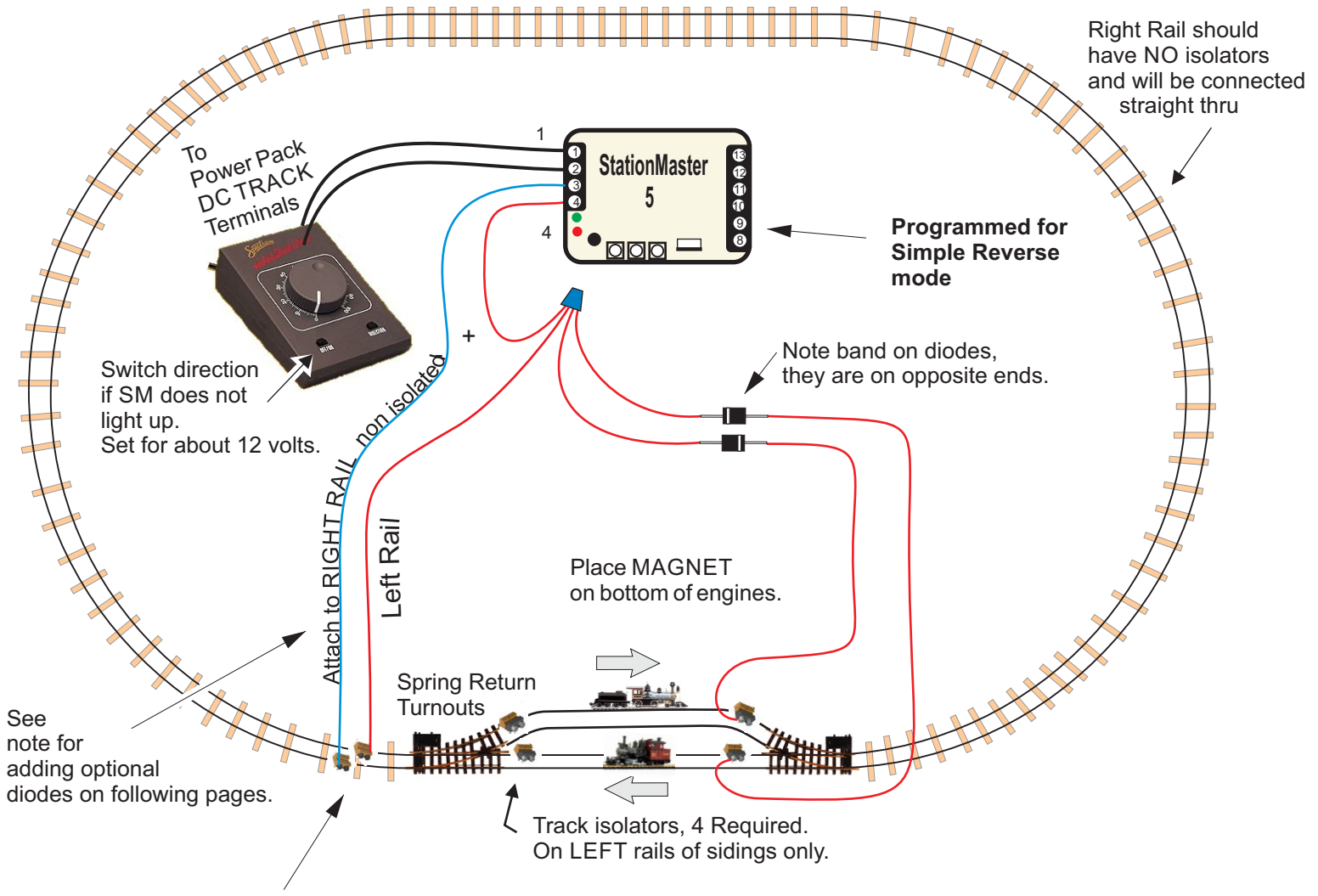

These are just connections to the rails. Non isolated. The right rail should be connected all around.

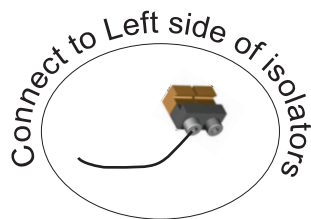

If powered turnouts are necessary use the YardMaster hookup



## Alternate 2 Trains at a Siding, Trains Travel Opposite Directions, SPRING-RETURN TURNOUTS

### SENSOR CONNECTIONS

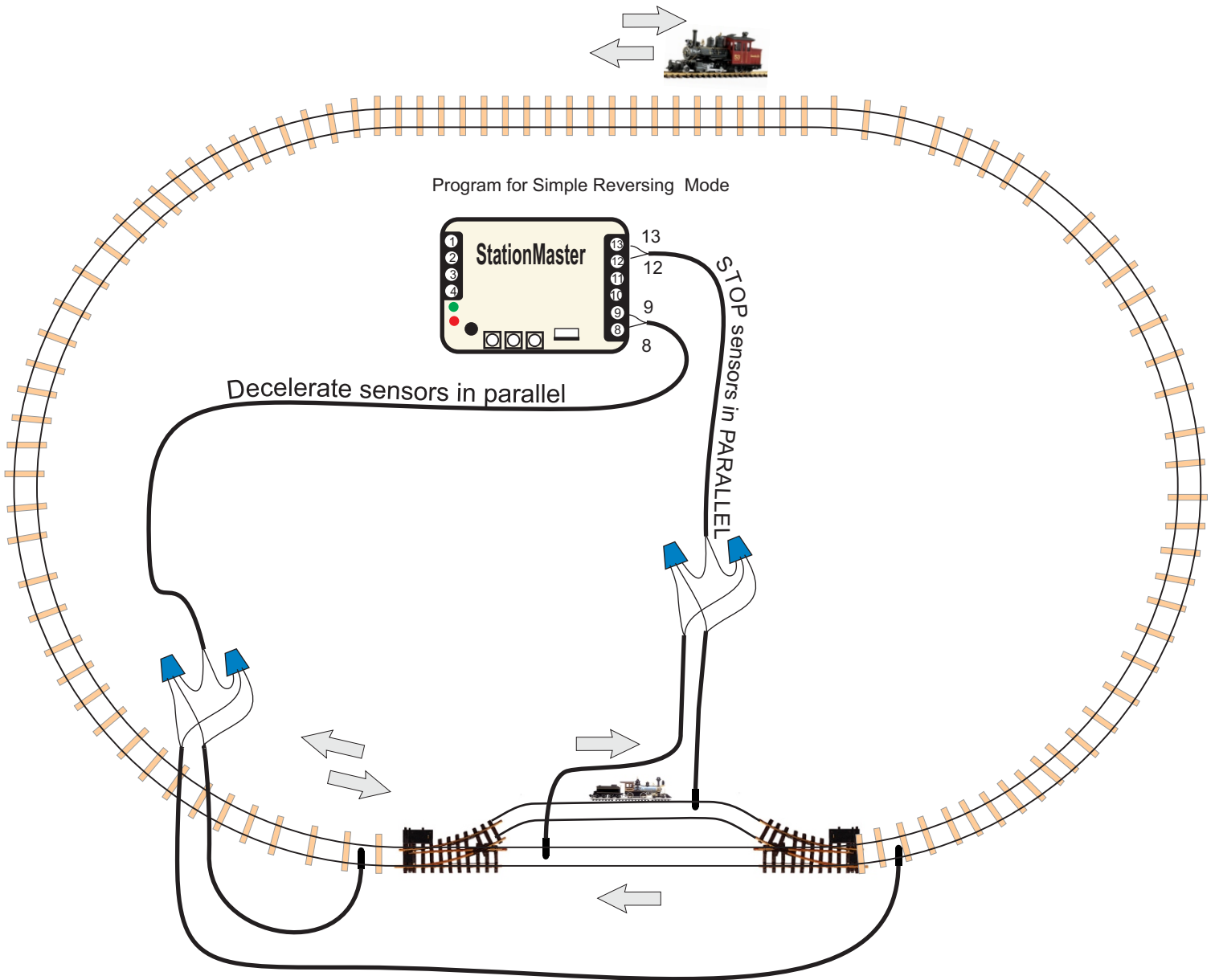
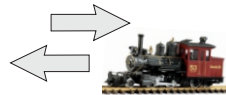

For additional station stops around the loop see "Justa-Station-Stop" in the StationMaster manual.



## Alternate 2 Trains at a Siding, Trains Travel Opposite Directions, SPRING RETURN turnouts

### Parts Required:

StationMaster:	Qty 1	4 AMP or 10AMP version.
Turnouts:	Qty 2	(Both spring return)
Track Isolators:	Qty 4	
Magnets:	Qty 2	(or one per train)
Sensors:	Qty 4	
Diodes:	Qty 2	

### Description

The Alternating 2 train siding will allow 2 trains to run around the layout in opposite directions. One of them will always be in the siding while the other train will be traveling. Trains will realistically decelerate and then creep into the station.

### StationMaster Hookup:

Terminals 8 and 9 are the DECEL sensor inputs and attach to the DECEL sensor as shown. (No polarity) Each sensor is located where the deceleration will start. Sensors are wired in parallel.

Terminals 12 and 13 are the STOP sensor. Attach these to the STOP sensors in each siding wired in parallel as shown. (No polarity) The train will stop just past this sensor.

Terminals 1 and 2 attach to the transformer. Change the train direction on the transformer if the StationMaster does not light up.

Terminal 3 attaches to RIGHT RAIL which is common ground throughout.

Set the transformer to the desired top speed of the train.

### StationMaster Programming:

- 1) Start with a factory reset for all values.
- 2) Program the deceleration rate to MAXIMUM.
  - a) Turn top speed dial fully counter-clockwise.
  - b) Press and hold down button #1 until the LED flashes quickly then release.
  - c) Turn the top speed dial fully clockwise.
- 3) Program for "Simple Reverse Mode".
  - a) Turn top speed dial full counter-clockwise.
  - b) Turn top speed dial slowly clockwise until the GREEN LED goes on.
  - c) Press and hold button #1 for 1 blink and release.
  - d) After blinking has stopped turn top speed dial fully clockwise.

#### Optional Programming:

- \* Multiple laps before stopping
- \* Acceleration Rate
- \* Pause time at station

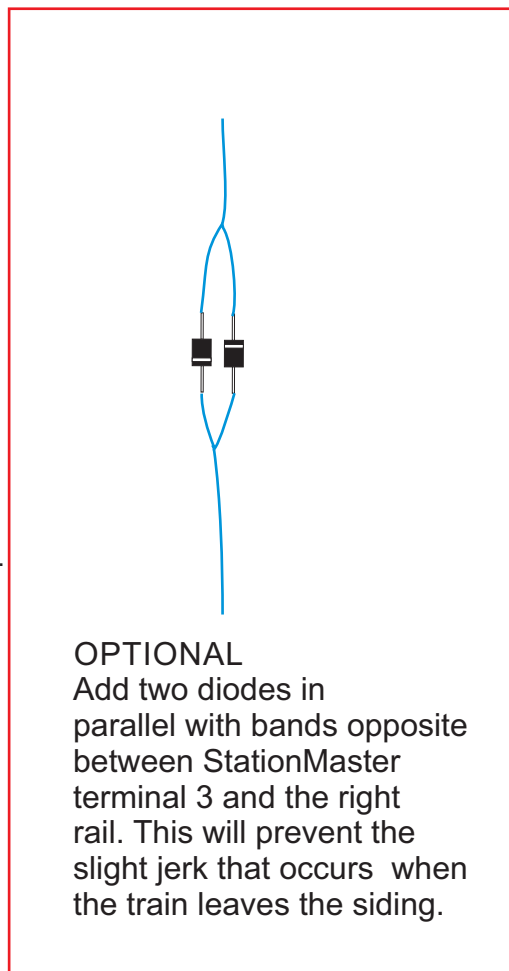

## Electrical Details

For reference only

The locations of the common grounds could be useful for some wiring harnesses.

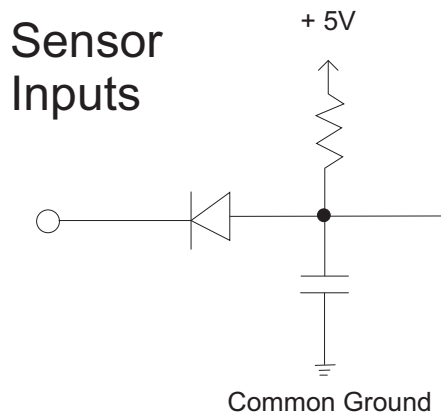
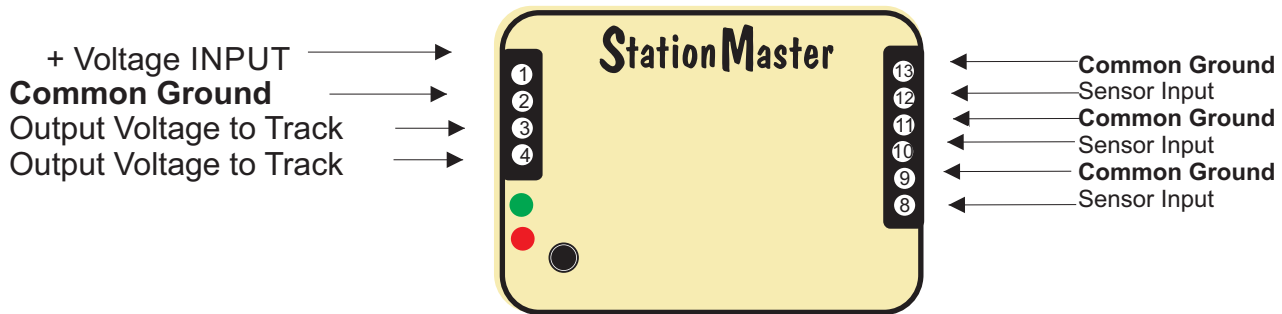

### Sensor Placements on Track

The suggested sensor placement on track is shown below with the train magnet installed in the center of the train. Best sensing is done with the magnet passing over the tip of the sensor.

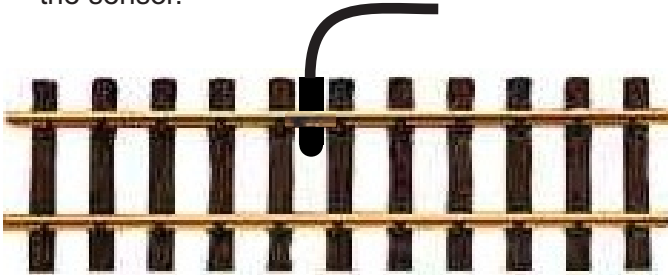

### Sensor Placement for identifying a train.

Offset the train's magnet to the same side as the sensor as shown.

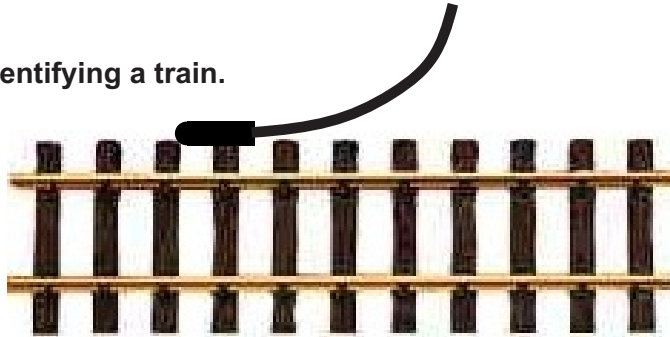

For example, passenger trains have the magnet offset to the right and freight trains have the magnet offset to the left side.

### Sensor placement for HO EZ track is under the roadbed.

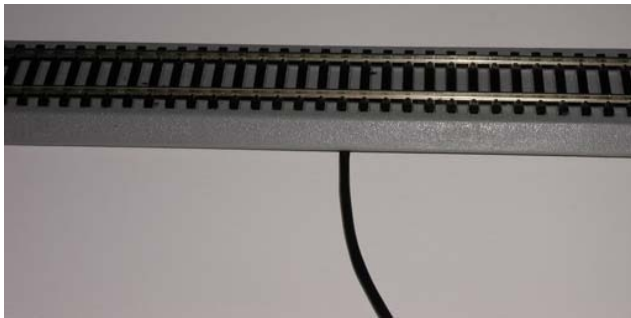

Other scale trains can place the sensors where appropriate. Very small sensors are available which do not have the waterproof housing. These smaller sensors can be used for N, HO, etc. Contact RR Concepts for these sensors.

<b>WARRANTY</b>
Your StationMaster is warranted, and guaranteed operational for 1 year. It will be repaired or replaced at no charge within that time period. Contact <a href="http://www.RR-Concepts.com">http://www.RR-Concepts.com</a> for additional information.