



# StationMaster - 5

## Reversing Train Controller

This manual contains detailed hookup and programming instructions for the StationMaster - Reversing train controller.

The Reversing StationMaster is similar to a standard StationMaster however it contains software to perform automatic back-and-forth operation with or without sensors.

**Before we Start-** Please do not attach power wires (from your power pack or transformer) to any other terminals except the designated inputs.

Your StationMaster will be damaged if power is put on any of the sensor terminals.

**ONLY ATTACH WIRES WHILE THE POWER IS OFF.**

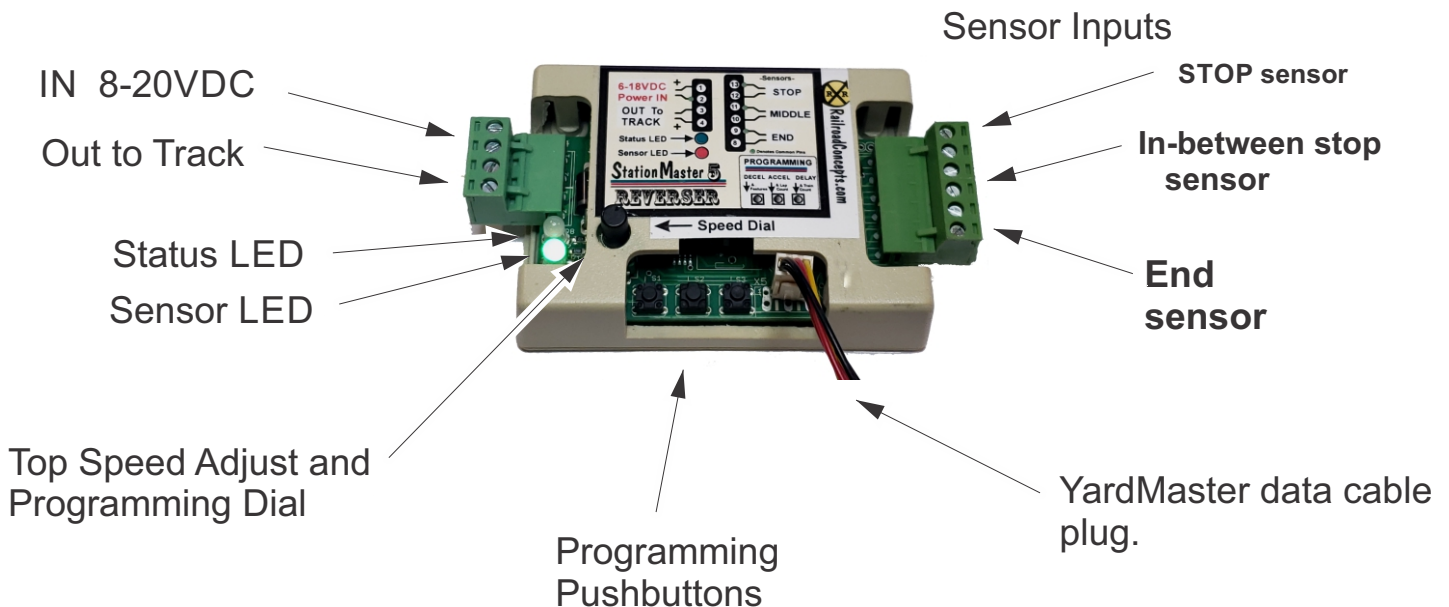

## StationMaster - 5 REVERSER

### Reversing Operations - with Accelerations & Decelerations No Sensors

The default hookup uses diodes at the ends which will stop the train when it crosses the boundary. If desirable, LGB 10151 units can be use in place of diodes.

#### PROGRAMMING:

Best performance is achieved with the **factory default settings**. (See factory default programming instructions) If desired the acceleration, deceleration and time delays can be changed.

Here is the hookup:

- \* 2 wires from the transformer to the Reverser.
- \* 2 wires from the Reverser to the track.
- \* Diodes on the ends where the engine will stop.

### Reversing using Diodes

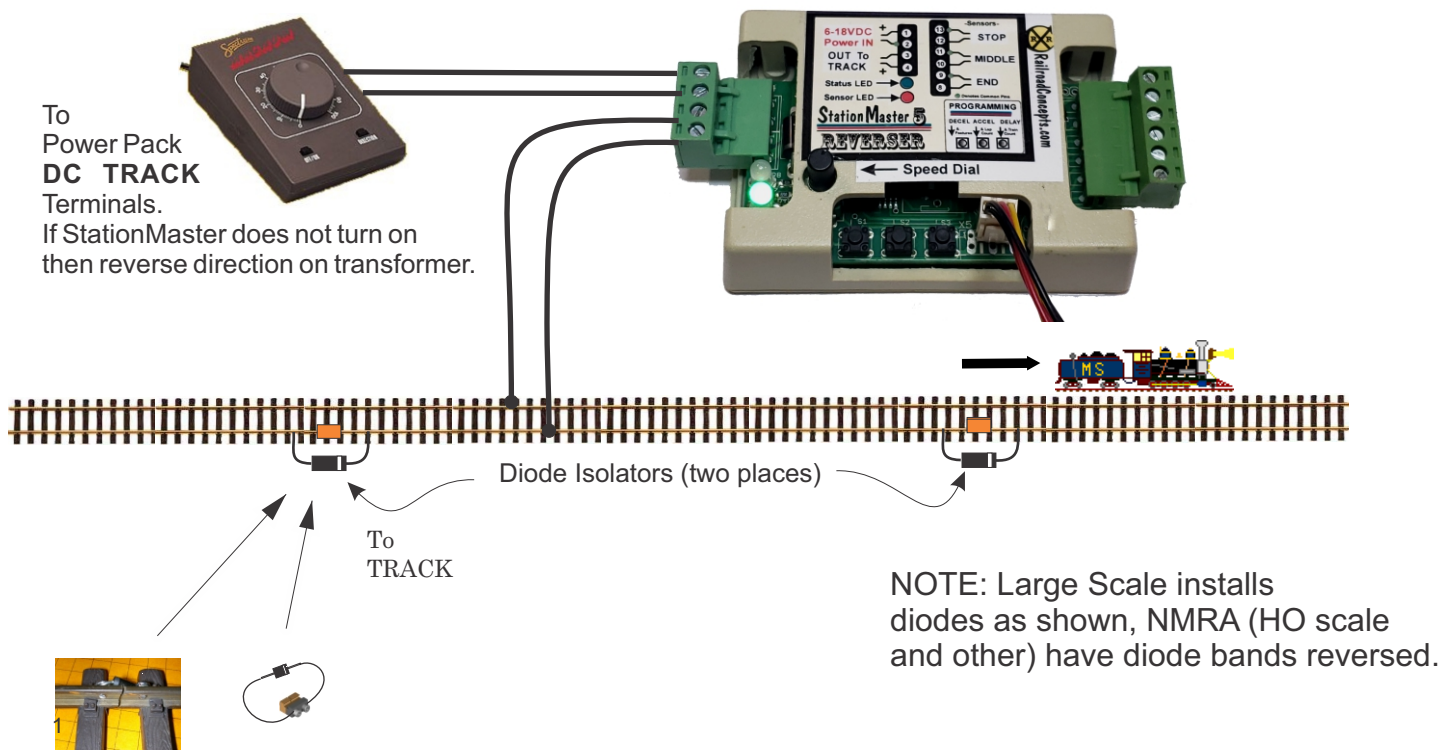

Diodes can be wired to the track using self-tapping screws or attached to an isolator. A 1 AMP diode is sufficient. (Part number 1N4001)

continued...

## Reversing Operations - No Sensors Continued...

### The operation In a Nutshell:

Since trains go different speeds for the different directions, the StationMaster allows setting a deceleration location for each direction. This, in addition to the acceleration and deceleration operations makes the StationMaster/Reverser unique to all other reversers.

The basic operation is as follows:

- When stopped on one of the ends, the train will reverse and accelerate up to the top speed.
- Once the TIME TO DECELERATE has been reached the train will decelerate down to a creeping speed.
- The creeping speed is set by turning the speed dial on the StationMaster.
- Eventually the train will cross the diode and stop.
- After the time delay, the process is repeated for the other direction using the TIME TO DECELERATE for that direction.
- If in-between stops are desired, a single sensor is placed at the stopping location. The time delay for the in-between stop is fixed at 10 seconds.

### How to Program in a Nutshell: (More details to follow)

After a reset, button #3 needs to be pressed three times; the first press is when the train stops on one end. This tells the StationMaster that we are at an extreme end and are ready to begin programming. After each button press the StationMaster will reverse. At about 2 or 3 feet from the end button #3 must be pushed a second time. This will record the time when the deceleration will start. After the pause and reverse button #3 must be pushed a third time at about 2 or 3 feet from the end. This will record the time when the deceleration will start for the return direction. This is a one-time operation to set the TIME TO DECELERATE values for each direction. These times are stored in flash memory and retained. Note that button #3 can be pressed at any time to set the TIME TO DECELERATE value while running. This allows perfect operations if the transformer speed is changed without performing a StationMaster reset.

## Reversing Operations - No Sensors Continued...

OPERATIONS: *Basically watch the train, and set the location where the deceleration should start*

- The Reverser has a 2 step speed profile. Speed #1 is the top speed of the train set by the transformer. Speed #2 is a “creeping” speed which allows the train to always reach the diode isolators on the ends.
- The Reverser will accelerate using the programmed acceleration rate, maintain a top speed, and then decelerate down to Speed #2 when the TIME TO DECELERATE time is reached.
- Once the deceleration has completed, Speed #2 will be maintained for the duration of the “pause time”. This provides a very realistic and smooth operation. After a reverse, the operation is repeated.

### HOW TO SET OR RESET REVERSING OPERATION:

**One time only. Settings are retained in flash memory.**

1. **Set the transformer for the desired top speed of the train and turn the StationMaster top speed dial fully clockwise.** For consistent operation try to resume to this speed each time the train is turned on.
2. **Press programming buttons #1 and #2 at the same time OR perform a factory reset.** This will erase any programmed TIME TO DECELERATE values. Note that this is not always necessary since the TIME TO DECELERATE can be changed at any time. (see below, pressing button #1 will also reset)
3. **Watch the train and press BUTTON #3 when the train reaches the TIME TO DECELERATE location.** This is typically 3 feet from the ends, but depends on the speed of the train and the programmed deceleration rate. The train will blink red and decelerate. After decelerating, the Reverser will blink RED/GREEN while the train creeps into the stops. After reversing, repeat for the other direction. Notice that the Reverser will store different TIME TO DECELERATE values for each direction since trains don't always go the same speed in forward and reverse.

## That's it!

### Pushbutton Operations

Dial: - optional -  
Turn down to decrease the “creep speed”.  
Note: Turning too far will enter programming mode.

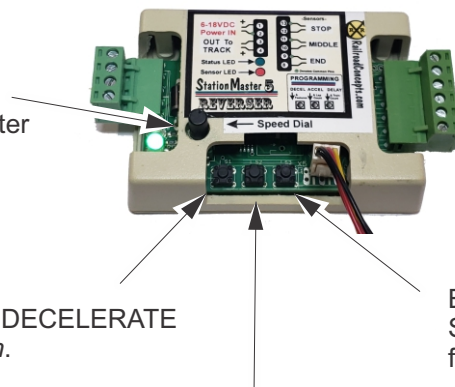

Button 1:  
Clear TIME TO DECELERATE  
for this direction.

Button #3:  
Set the TIME TO DECELERATE  
for this direction NOW.

Button #2: - optional -  
Terminate the time delay operation  
and reverse as soon as possible.  
(Convenience during programming)

Continued...

## Reversing Operations - No Sensors Continued...

### Notes

Most important- Always allow the trains to enter the stops on the ends before setting the TIME TO DECELERATE value (button #3). We need to record the time to start the deceleration for the full length of track, including any in-between stops.

### LED Indications

***This LED will:***

Flash GREEN when accelerating,  
Flash RED when decelerating,  
Slowly flash GREEN/RED during the time delay.

***This LED will:***

Turn RED when a TIME TO DECELERATE value is **NOT** set for this direction.

Button #3 **MUST** be pressed to set the deceleration time or the train will never reverse.

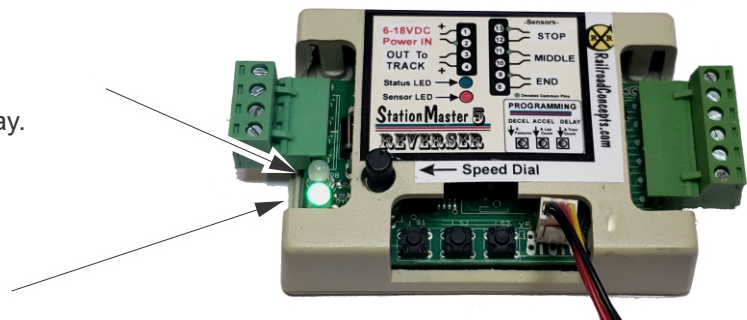

### Pushbutton and Dial Operations - a few more details

All recorded values are stored in flash memory and retained after a power cycle. For consistent operation day after day the transformer throttle setting should be the same. Sometimes trains will run a different speed after operating for awhile, and this is expected. To always creep into the ends set the TIME TO DECELERATE location sooner to allow more creep time.

The duration of the creep time is set from the programmed delay time. The delay time is actually “*creep this long before reversing*”, however once the train passes the diode it will stop. Essentially the programmed time delay is creep time + stopped time. Setting the TIME TO DECELERATE location sooner will decrease the stopped time and vice-versa. Just change the time delay value as needed.

When the Reverser is running, button #3 can be pressed at any time to set a new TIME TO DECELERATE.

If the deceleration is starting too soon and a different time is desired, then press **BUTTON #1** to erase the stored value for this direction. This will cause the Reverser to set an infinite time delay and allow the train to creep into the stops (orange blink). Once the train enters the stops, press **button #2** (terminate the time delay) to continue. Set a new TIME TO DECEL value again after the train reverses and comes back in this direction.

The default creep speed is relative to the transformer throttle setting. If a slower creep speed is desired, then turn the top speed dial counter-clockwise to slow the train down. Note that the creep speed will be the same for both directions. Some trains will creep faster in forward than in reverse. Note that the StationMaster requires at least 8 volts to operate.

## In-Between Station Stops

For in-between stops, attach a sensor to terminals 10 and 11. When the magnet on the train triggers the sensor the train will pause at the station. For more than one stop add more sensors in parallel.

Note that The deceleration rate is rapid and the time duration for the stop is fixed. This allows the train to stop at approximately the same location for each direction.

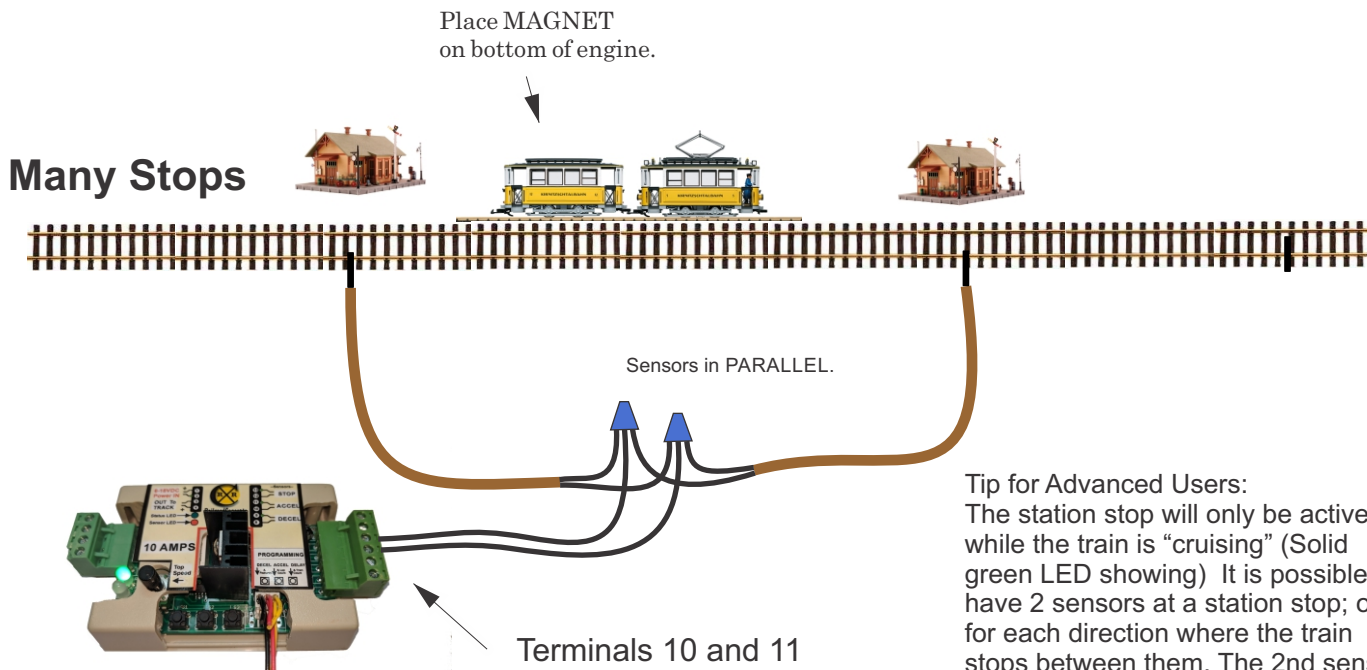
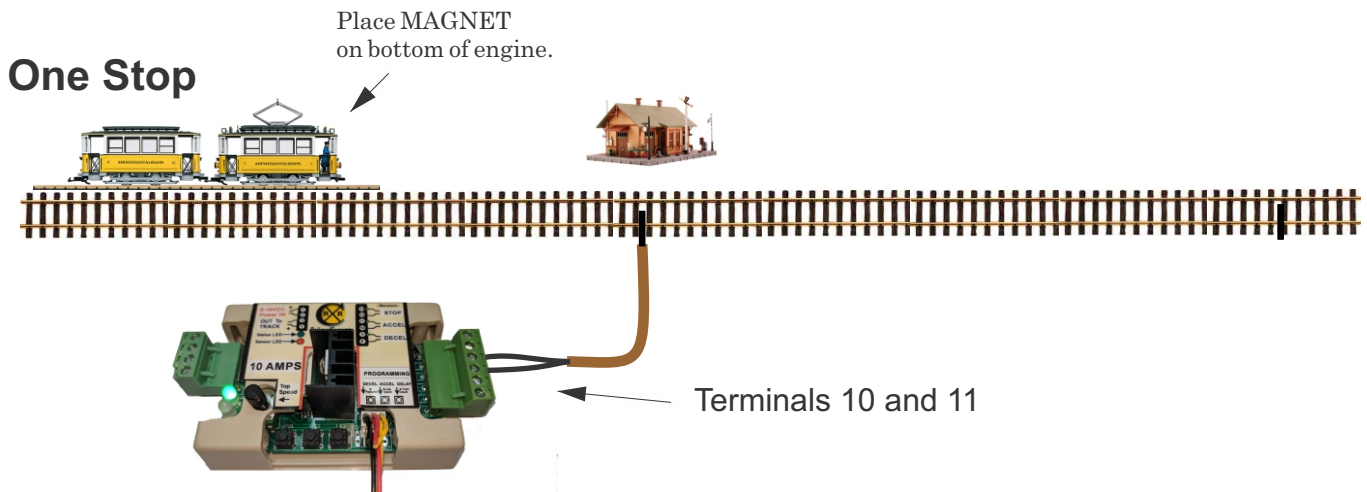

Tip for Advanced Users:  
The station stop will only be active while the train is "cruising" (Solid green LED showing) It is possible to have 2 sensors at a station stop; one for each direction where the train stops between them. The 2nd sensor encountered would be ignored while the train is accelerating.



## Reversing Operations using Sensors

When sensors are used the StationMaster will reverse before every acceleration and ignore the next DECEL sensor it encounters after a reversal. Using sensors provides a more consistent day-to-day operation regardless of changing speeds changing trains, etc. This is a more reliable operation for multiple train sidings where the trains travel at different speeds.

This hookup requires a sensor to be placed on the extreme ends to signal the StationMaster to begin the deceleration/pause/acceleration sequences. Diodes on the ends are not necessary but recommended to prevent the train from ever running off the end.

### Reversing using Sensors

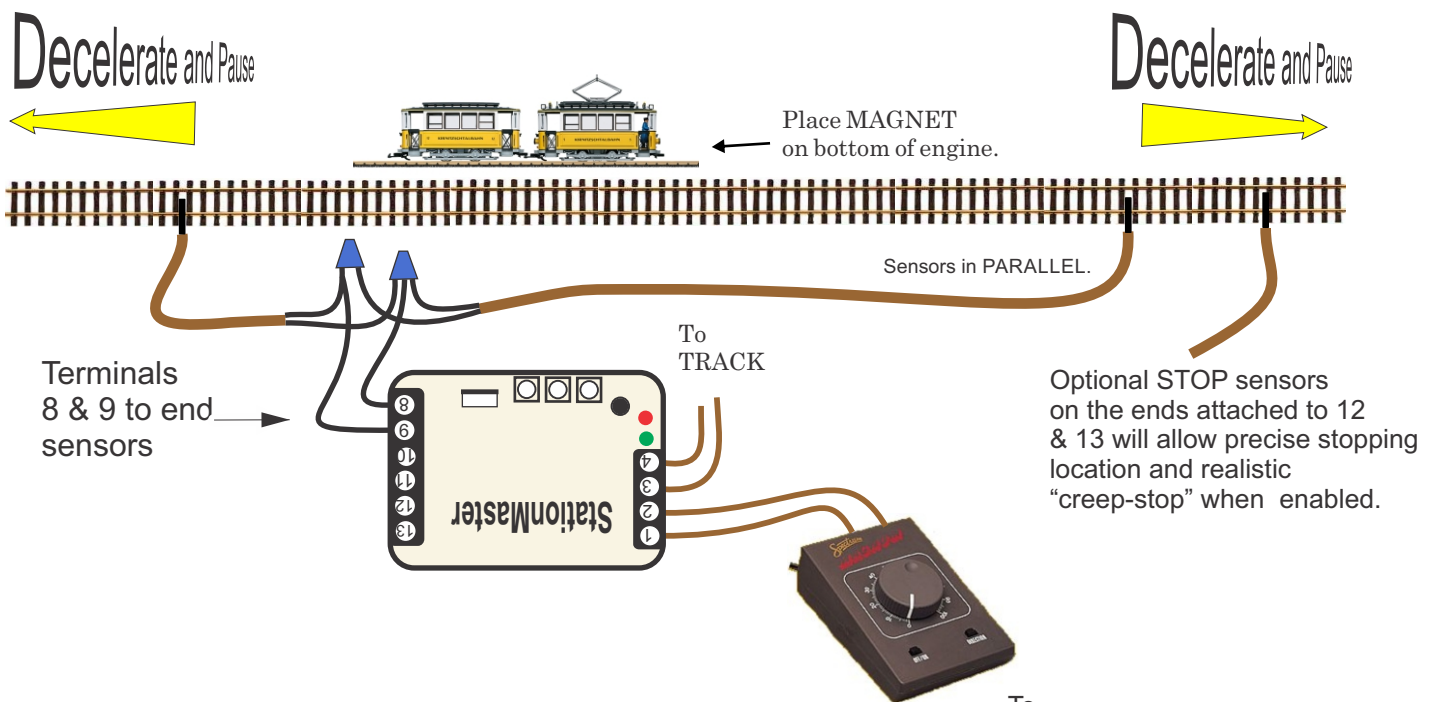

**PROGRAMMING:**  
 Set programming blink 1 to use sensors.  
 (See programming instructions for more info)  
 Set acceleration and deceleration rates as desired.  
 Set time delay on ends as desired.

To  
 Power Pack  
 DC TRACK  
 Terminals.  
 If StationMaster does not turn on.  
 reverse direction on transformer.

## StationMaster Basic Hookup Description

The StationMaster is designed to be installed between the train transformer, and the track.

Attach terminals 1 & 2 to your transformer's DC output (Sometimes labeled as TRACK) or to a constant 12 volt power source. If using a train transformer set the throttle position to the desired top speed of the train. If the StationMaster does not "light up", then reverse the direction on the transformer to change the voltage polarity, or swap these two wires.

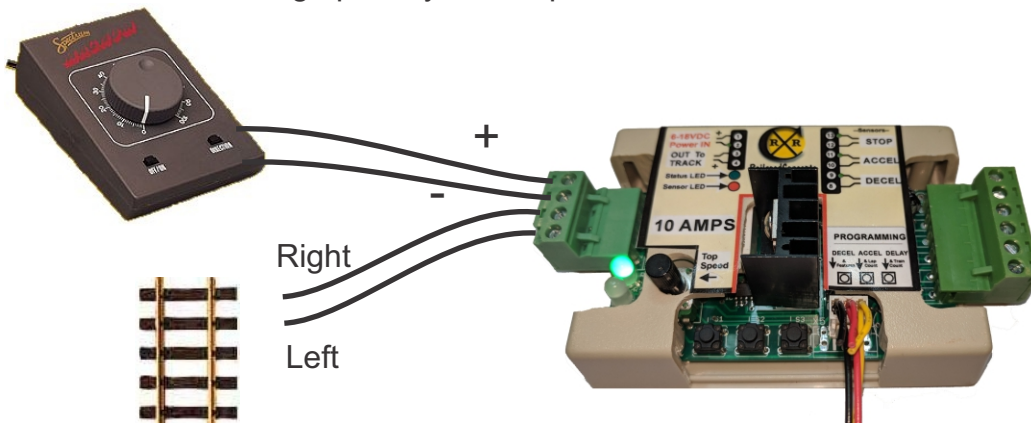

Attach 3 & 4 to your track. This is the controlled output voltage that accelerates and decelerates the train. Pin 3 will be the "common" wire which is the *right rail* for Large Scale trains or the *left rail* for NMRA standard trains.

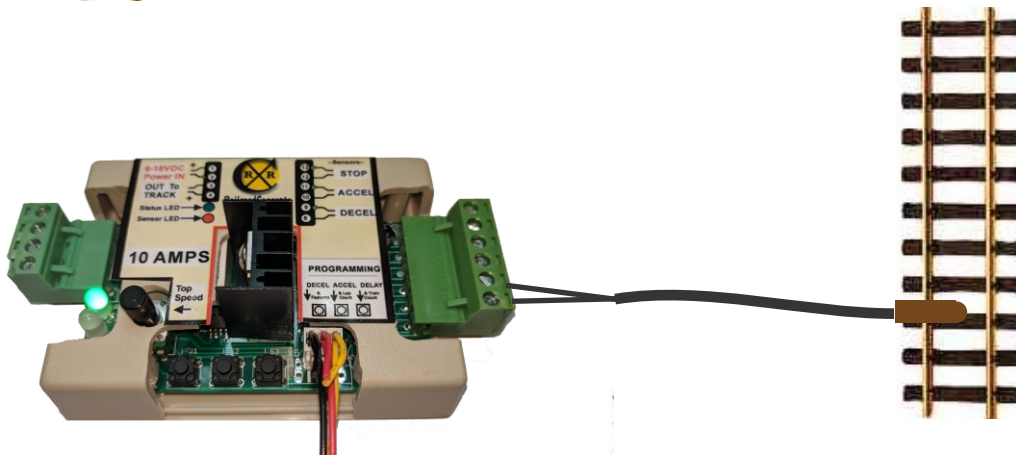

### END Sensor - only when programmed to use sensors.

Terminals 8 & 9 are the start DECEL sensor for the ends. When this sensor detects a magnet the StationMaster will begin a decelerate, pause, reverse, and then accelerate sequence. The sensor LED will light up when this sensor is detected. The DECEL sensor should be placed 1 or 2 feet from the ends, depending on the deceleration rate. One is required on each end.



**\*This sensor can be simulated by pressing button #1.**

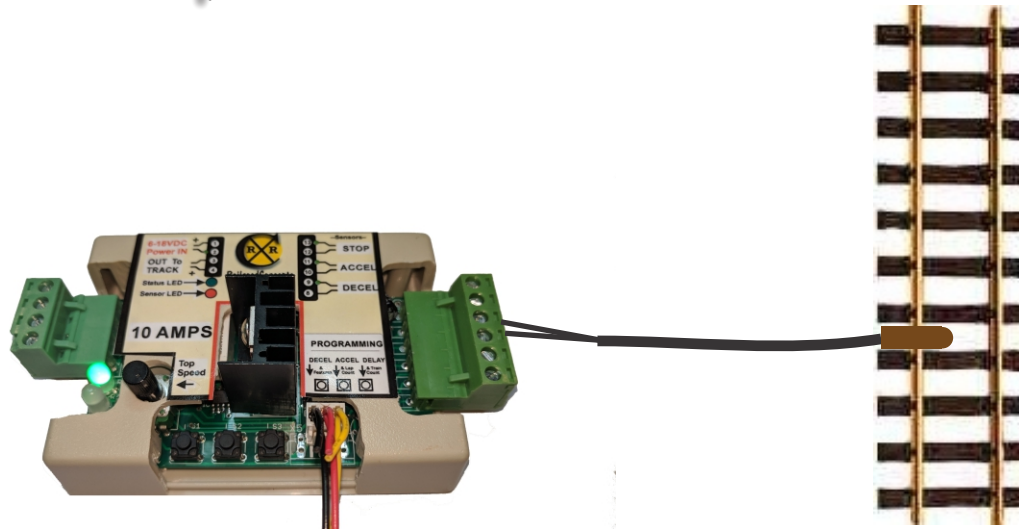

## In-between station stop Sensor

Terminals 10 and 11 will perform an in-between station stop.

When this sensor detects a magnet the StationMaster/Reverser will perform an in-between station stop without reversing using a fixed time delay.



**\*This sensor can be simulated by pressing button #2.**

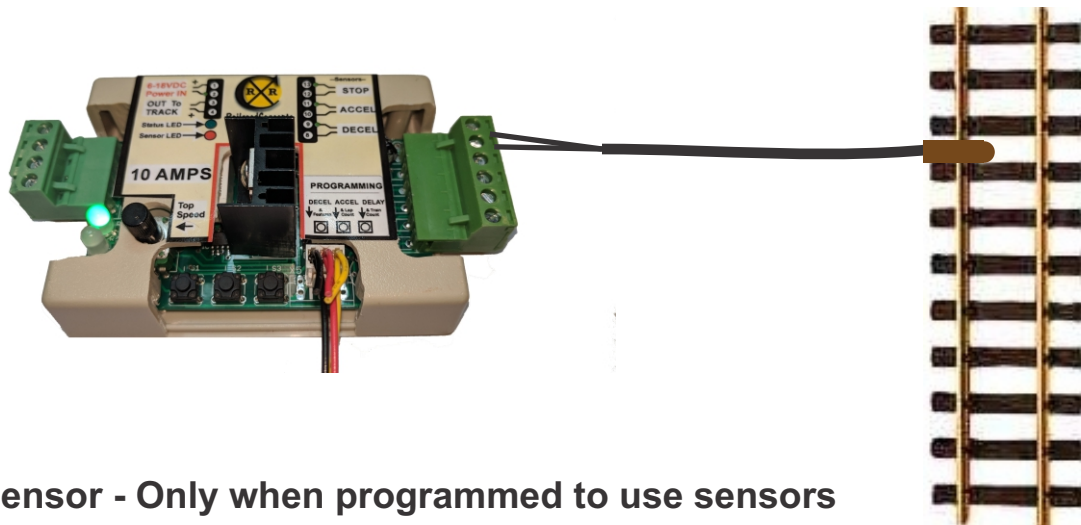

Optional

## STOP Sensor - Only when programmed to use sensors

Terminals 12 and 13 are the optional STOP sensor inputs.

**When the train is decelerating** and this sensor detects a magnet, the train will immediately STOP. This sensor is not necessary unless using the “Creep-stop” feature in which case this sensor is mandatory.

The STOP sensor will have no affect unless the train has already passed over the DECEL sensor.



**This sensor can be simulated by pressing button #3.**

## Top Speed and Programming Mode Dial

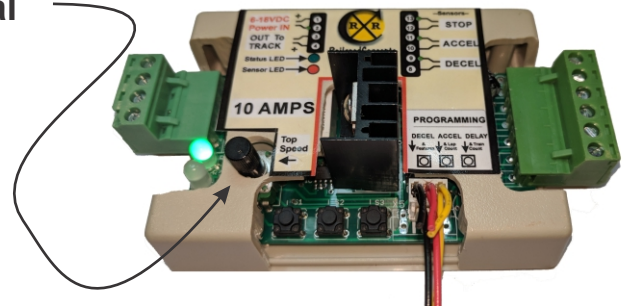

The Top Speed dial provides 2 functions:

- 1: Adjust the speed of the train.
- 2: Enter programming mode.

### For Diode Reversing operations: (The default no-sensor condition)

#### Creeping Speed Adjustment

When creeping into the diode section this dial will reduce the creeping speed. Turn down as desired. Notice that this speed is the same for both directions. Trains typically go different speeds in each direction, so choose a speed that works for both. The speed is relative to the transformer setting, so setting the transformer to the same speed each time will produce more repeatable results.

### When programmed for sensor reversing:

#### Top speed adjustment

“Full speed” is clockwise. Turn this dial down as necessary to set the desired cruising speed of the train. This is only necessary when using a “fixed voltage” power supply or when a YardMaster is attached and a slower top speed is desired.

**Typically, this dial is set fully clockwise and the train transformer is used to set the speed of the train.**

---

#### Programming Mode

To enter programming mode turn this dial fully counter-clockwise. The Sensor LED will display orange to indicate “programming mode”.

The acceleration rate, deceleration rate and time delay can be programmed in this state. See the programming details or decal on bottom of the StationMaster for additional information.

To exit programming mode turn the dial fully clockwise.

## LED indicators

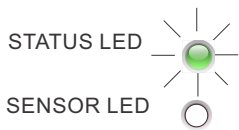
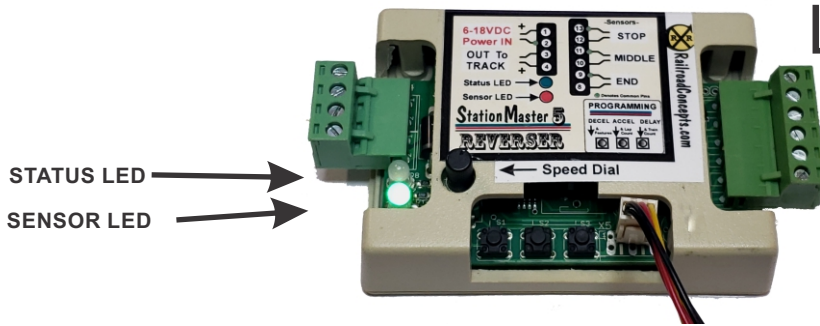

Green flashing: train is **ACCELERATING**.



Green NOT flashing: Train is **AT TOP CRUISING SPEED**.



Orange NOT flashing, StationMaster **will ignore next DECEL sensor**

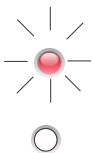

1. Quick Red flashing: Train is **DECELERATING**.

2. Red/GREEN flashing at 1 second rate: StationMaster is performing a time delay, or possibly creeping into the stops.



Diode Reverse Mode: The *TIME TO DECELERATE* is not set for this direction.



Sensor Mode: A sensor is detected.

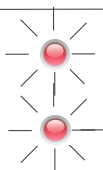

Two Red Blinking LED's indicate a **SHORT CIRCUIT** condition. To resume, power down or press and hold button #1 for 5 seconds. If condition returns when it should not, then re-program shutdown threshold: Set transformer to full speed then press and hold button #3 for 5 seconds.



Sensor LED GREEN twinkling indicates secondary Programming mode.



Sensor LED orange twinkling indicates programming mode.



*Programming:*  
**Deceleration Rate**

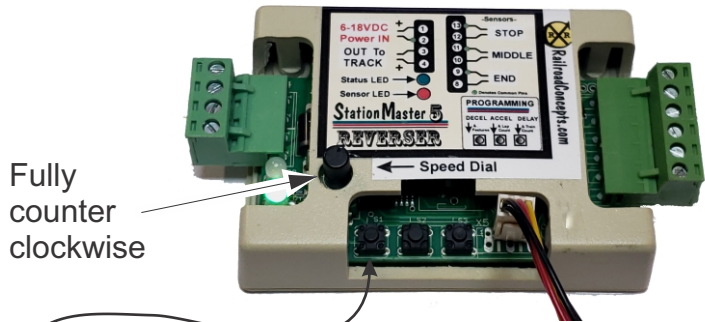

1. Make sure all three sensor inputs are open.
2. If the top speed dial is not already at zero, then turn the top speed dial to zero. (fully counter-clockwise.) The sensor LED will turn ORANGE.
3. Push and hold programming button #1.
4. Watch the status led. Each RED blink will decelerate slower.  
The fastest deceleration will be with one blink. (TRAIN Stops sooner) Release the pushbutton when the desired number of blinks have occurred. A typical number is 5. Repeat this procedure if you want a different value.

One blink corresponds to a 3 second deceleration rate. Each additional blink adds 1 second. For example, a blink count of 5 would result in a deceleration rate of 8 seconds.



When finished with all programming turn the top speed dial fully clockwise and then turn down to a desired creeping or top speed if needed.

All programming values are stored in flash memory and are retained until re-programmed.

When “Creep Stop” is enabled the StationMaster will adjust the deceleration rate on each cycle to provide a perfect stop. The programmed value can be anything but a good starting value will dial in the StationMaster faster.



## Programming: Acceleration Rate

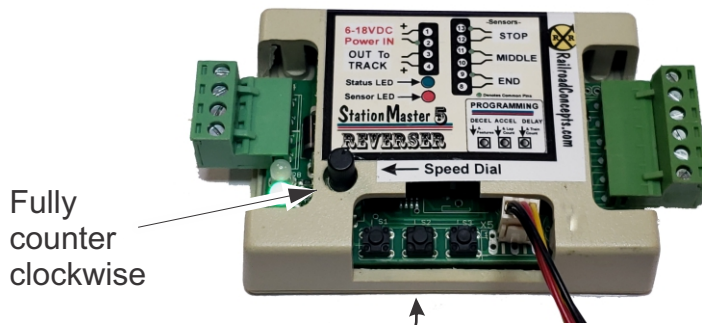

1. Make sure all three sensor inputs are open. (Red LED is off)
2. If the top speed dial is not already at zero, then turn the top speed dial to zero. (fully counter-clockwise.) The sensor LED will turn ORANGE.
3. Press and hold programming button #2..
4. Watch the status led. Each GREEN flash will accelerate slower.  
The fastest acceleration will be with one blink.  
Release the button when the desired number of blinks have occurred.  
A typical number is 5. Repeat this procedure if you want a different value.  
One blink corresponds to a 3 second acceleration time. Each additional blink adds 1 second. For example, a blink count of 5 would result in a deceleration rate of 8 seconds. A factory default will set to 5.



When finished with all programming, increase the top speed dial clockwise to MAX and then down to a desired top speed. All programming values are stored in flash memory and are retained until re-programmed.

### A Note on Realistic Accelerations:

- \* For blinks 1 thru 9 the train will accelerate linearly with the programmed value. This may be required for some block control operations where a second train is approaching and the first train needs to quickly accelerate to get out of the way, or for a trolley which accelerates quickly.
- \* For blinks 10 and above the train will creep very slowly out of the station and then continue accelerating as it continues down the main line. This provides a very realistic operation as a train creeps out of a siding or station and shows off sound systems with incredible realism.
- \* 10 blinks will creep for 5 seconds.
- \* 11 blinks will creep for 10 seconds.
- \* 12 blinks and up will creep for 15 seconds.



Fully counter clockwise

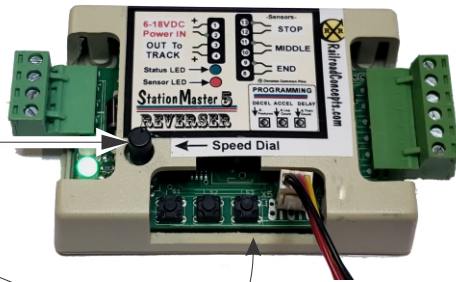

## Programming: Pause Time

1. Make sure all three sensor inputs are open. (red Led is off)
2. If the top speed dial is not already at zero, then turn the top speed dial to zero. (fully counter-clockwise.) The sensor LED will turn ORANGE.
3. Press and hold programming button #3.
4. Each ORANGE flash will increase the waiting time after a station stop. A wait time of zero will be with one flash. Release the button when the desired number of flashes have occurred. Repeat this procedure if you want a different value.

The LED will flash orange when an infinite delay is set (after 13 counts).

**When infinite delay is set, then the ACCEL sensor is required to start up the train after a station stop.** A fun thing to do would be to connect the ACCEL terminals to a doorbell switch. Your train would patiently wait until someone pushed the button! Motion sensors are another possible way to start the train.



When finished with all programming increase the top speed dial clockwise to maximum or to a desired top speed. All programming values are stored in flash memory and are retained until re-programmed.

The number of orange FLASHES will correspond to the following time delays:

- 1: 0 seconds, no wait.
- 2: 5 seconds
- 3: 10 seconds
- 4: 15 seconds
- 5: 20 seconds
- 6: 30 seconds
- 7: 1 minute
- 8: 2 minutes
- 9: 5 minutes
- 10: 10 minutes
- 11: 30 minutes
- 12: 60 minutes
- 13: Infinite, wait for GO sensor. This is for block control operations.

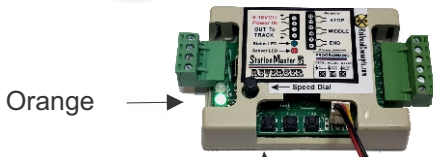

Please go to [RRconcepts.com](http://RRconcepts.com) to view an informational video on how to program operating modes.

## Programming: Operating Modes

HOW TO PROGRAM: (Perform a factory reset to clear everything if needed)

1. **Enter Secondary Programming mode:** (Skip this step if already in secondary programming mode)

- \* Turn the Top Speed dial fully counter-clockwise to enter programming mode (Skip this step if already in programming mode). The sensor LED will turn **ORANGE**.
- \* Turn the Top Speed dial slowly clockwise until the sensor LED turns **GREEN**. This indicates secondary programming mode. This should be about half-way.



2. **Press and hold programming button #1** until the desired number of blinks have occurred. Each blink will set or clear a different feature. If currently ON it will turn off. If OFF it will turn ON. **When finished do not power off without first turning the dial fully clockwise.**

### Programmable Modes: (Any or all of these or all can be programmed independently)

- Hold button for 1 blink = Sensor Reversing Mode, ignore next sensor after reversing, ACCEL sensor will perform an in-between station stop.
- Hold button for 2 blinks = Fire YardMaster before acceleration starts.
- Hold button for 3 blinks = Fire YardMaster after train has stopped. (Default ON after a factory reset)
- Hold button for 4 blinks = Sensor mode only: Reverse direction before every acceleration. Never ignore sensors.
- Hold button for 5 blinks = Only fire YardMaster in forward direction. (For reversing operations with a siding on one end)
- Hold button for 6 blinks = Shut off current sensor. This could cause damage to the StationMaster unless the transformer can provide short-circuit shutdown. This is sometimes necessary when running with very small transformers. (1 AMP or less)
- Hold button for 7 blinks = Sensor mode only: Turn on "creep stop". The train will decelerate then creep until reaching the STOP sensor. LEDs will flash RED/GREEN when creeping.

When the button is released the StationMaster will echo the currently programmed features (modes) by blinking the red/green LED 6 times. *For example*, if "Fire YardMaster after train has stopped" has been programmed (button pressed for 3 blinks) and nothing else is programmed then the StationMaster will blink:

- blink 1 RED: Sensor Reversing mode is OFF.
- blink 2 RED: Fire YardMaster before acceleration starts
- blink 3 GREEN: Fire YardMaster after stopping ON
- blink 4 RED: Reverse direction before every acceleration OFF
- blink 5 RED: Only fire YardMaster in forward direction OFF
- blink 6 RED: Disable current sensor: OFF
- blink 7 RED: Creep-stop mode : OFF

Each time a feature is "programmed" that feature will toggle on or off. (Toggle means the feature will go OFF if currently ON, or ON if currently OFF). A factory reset will clear all values and set bit 2.

**To view the currently programmed operating modes quickly press and release button #1.**

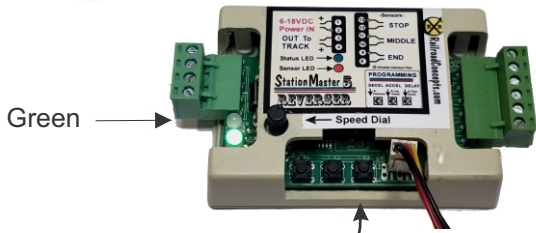

## Programming: Train Count

The train count is needed for 2 reasons:

1. Manage different creeping speeds for up to 5 trains. (sensor mode only)
2. Send proper signals to attached YardMasters to correctly fire turnouts.

For example, a 3 track siding using 2 YardMasters wired in parallel would have a train count of 3, since 3 trains will be controlled.

A factory reset will set this to 2 trains.

When running a simple back and forth this value can be anything.

### Programming:

1. Make sure all three sensor inputs are open.
2. If not already in programming mode turn the top speed dial to zero. (fully counter-clockwise.)
3. Slowly turn the top speed dial clockwise until the sensor LED turns GREEN. This indicates secondary programming mode. (Skip this step if already in secondary programming mode)
4. Press and hold button #3.
5. Each orange flash counts the number of running trains.

Release the button when the desired number of flashes have occurred.

The number will be echoed back when the button is released..

Repeat this procedure if you want a different value.

When finished with all programming, increase the top speed dial clockwise to MAX, and then down to a desired top speed or creep speed if necessary.

All programming values are stored in flash memory and saved until re-programmed again.



**NOTICE: A factory reset will set the train count to 2.**

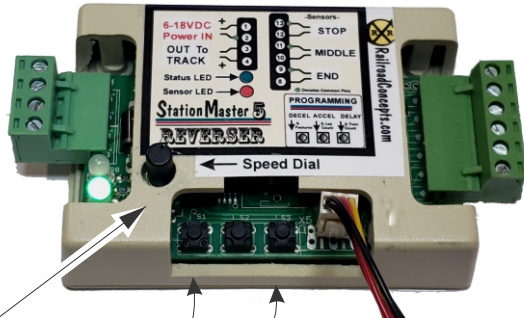

## Programming: Factory Reset

Fully counter clockwise

To set the StationMaster back to factory defaults perform the following:

- 1: Enter programming mode by turning the top speed dial fully counter-clockwise
2. Press and hold both button #1 AND button #3 at the same time.
- 3 Turn the top speed dial fully clockwise to exit programming mode.



**Do not power off without first turning the dial fully clockwise.**

The factory default settings are:

- \* Acceleration rate 1 blink.
- \* Deceleration rate 1 blink.
- \* Time delay 10 seconds.
- \* Train count: 2
- \* Creep settings reset
- \* Deceleration times reset
- \* Operating mode (features) set as follows:

- Blink 1 = RED, Sensor Reversing Mode: OFF.
- Blink 2 = GREEN, Fire YardMaster before accelerating:
- Blink 3 = RED, Reverse before every acceleration: OFF
- Blink 4 = RED, Fire YardMaster only in forward direction: OFF
- Blink 5 = RED, Disable current sensor: OFF
- Blink 6 = RED, Enable CREEP-STOP mode: OF

**When exiting programming mode the shutdown threshold current will be programmed. (Internal relays will briefly short the track and measure the amperage consumed). In order to obtain a good value the train transformer should be set to full speed while performing a factory reset. This is not always necessary, but will prevent false short circuit shutdowns when running with smaller transformers.**

## “Creep-Stop” Deceleration for Incredible Realism - Sensor mode only -

A unique and extremely realistic feature of the StationMaster is “Creep-Stop” Deceleration. By using both a DECEL sensor and a STOP sensor the StationMaster will provide a very realistic station stop. Programming your StationMaster to use “Creep-Stop” is very easy:

1. Set bit 7 in programming mode.(Press and hold button #1 in SECONDARY Programming mode until the LED blinks rapidly)
2. Place the **DECEL** and **STOP** sensors on your track as shown. The distance between sensors should be about 2 to 6 feet, or whatever looks good to you.
3. Program the deceleration rate (if needed) to provide a realistic deceleration into the train yard before the creep starts.

**That’s it!**

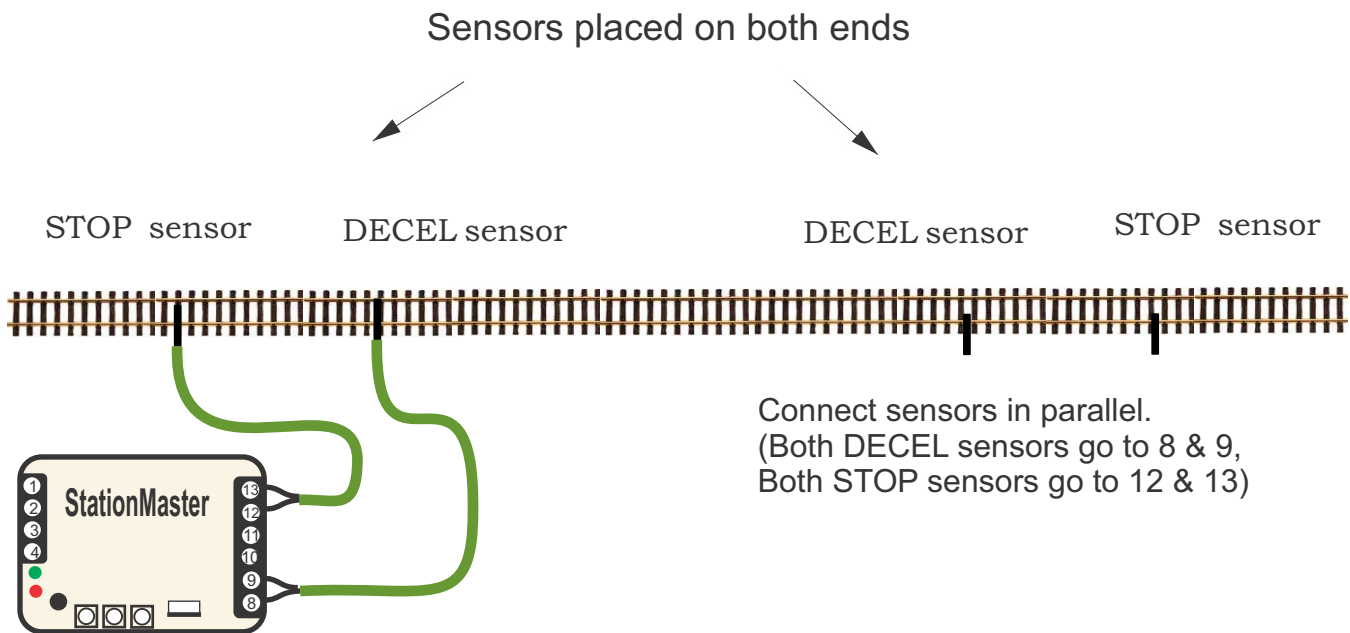

When “Creep Stop” is enabled, the train will decelerate then “creep” into the stop sensor using an optimum deceleration profile. The starting creep speed is relatively fast however the StationMaster will slow down on each cycle until it eventually stalls. **When the train stalls, then the creep speed is increased for the next time.** When a stall occurs, the voltage will be increased to allow the train to reach the STOP sensor. If the train does not reach the sensor within 25 seconds then the creep speed is increased. Be patient. when the train stalls it will eventually carry on to the sensor after 25 seconds.

The length of the creeping can be adjusted by increasing or decreasing the distance between DECEL and STOP sensors. The StationMaster will self-adjust the deceleration rate so that the train stops just before the stop sensor and then creeps to the sensor. Start with a 4 foot distance and see how that looks. The StationMaster will self-adjust each cycle to eventually produce a very realistic stop.

The StationMaster can control up to 5 different creep speeds for up to 5 different trains. Slow trains can run next to fast trains and each train will creep perfectly. Use the “train count” to set the number of trains that will be run. A factory default will set for 2 trains which is perfect for an alternating siding setup.

## StationMaster “Deadman Timer”

-Sensor mode only-

A unique feature of the StationMaster is the *DeadmanTimer*.

**If a train is sensed on the track and no sensor has been detected for 10 minutes**, then the StationMaster will SHUT DOWN and flash both the GREEN LEDs.

This prevents the condition where a train is hung up on an obstruction and spinning it's wheels, most probably grinding a divot in the rails and wearing out wheels and gears.

Each time a sensor is triggered, or the train is not sensed, the deadman timer is reset.

*The Deadman Timer will be enabled AFTER the first sensor or pushbutton is pressed after a power up.*

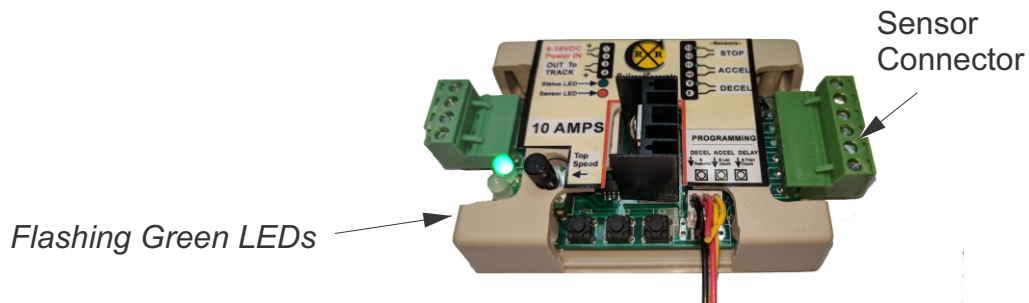

## Electrical Details

For reference only

The locations of the common grounds could be useful for some wiring harnesses.

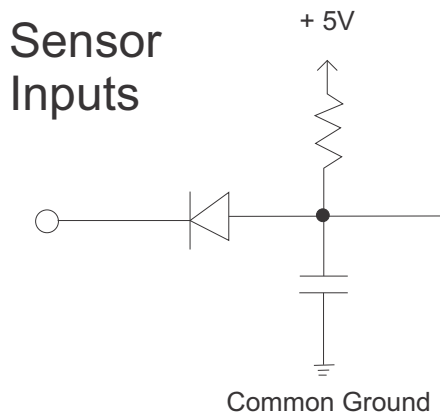
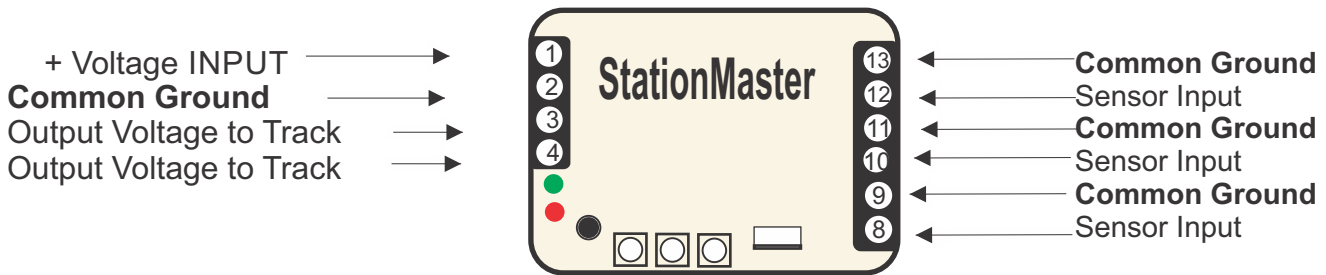



## Troubleshooting

### Problem:

The StationMaster goes into shutdown mode when it should not.

### Background:

When exiting programming mode the StationMaster turns on internal relays to short circuit the track for a brief amount of time. During this time the power entering the current sensor is measured and is then stored as the “shutdown” current. When the StationMaster detects this amount of current flowing through the track it will shut down assuming that there is a short circuit due to a derail, mis-wire, etc. Sometimes a low shutdown value can be recorded if the transformer is set to a low value during programming operations. If the transformer throttle is then turned up while running the StationMaster could sense an over-current and shut down.

### Solutions:

1. Perform a factory reset with the transformer throttle set at full speed.
2. When both red LEDs are flashing, turn the transformer throttle up to full speed and press button #3 for 5 seconds. This can only be done when both red LEDs are flashing.

### Problem:

No sensor mode: the train stops before reaching the ends.

### Background:

The time to start decelerating is set by button #3 and retained in memory, however the speed of the train could have changed due to a change in the transformer throttle position, change of train engine, or change in programmed acceleration or deceleration blinks.

### Solution:

Any one of the following will allow the train to run farther before stopping:

1. Turn the top speed dial clockwise to increase the creep speed.
2. Turn up the transformer throttle.
3. Increase the programmed time delay to allow more creeping before reversing.
4. Change the START DECELERATION spot to be closer to the ends. (Press button #1 to clear the programming for this direction and then press button #3 again to set the point where deceleration should start.)



## Sensor Placements on Track

The suggested sensor placement on track is shown below with the train magnet installed in the center of the train. Best sensing is done with the magnet passing over the tip of the sensor.

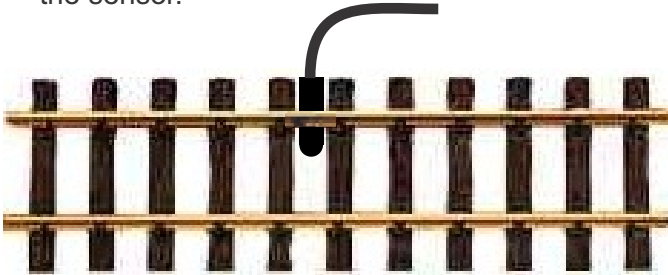

### Sensor Placement for identifying a train.

Offset the train's magnet to the same side as the sensor as shown.

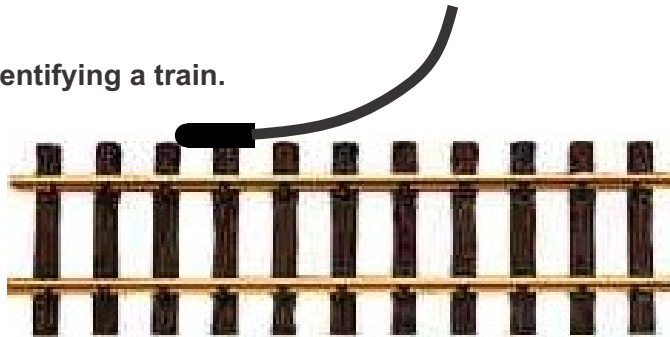

For example, passenger trains have the magnet offset to the right and freight trains have the magnet offset to the left side.

### Sensor placement for HO EZ track is under the roadbed.



Other scale trains can place the sensors where appropriate. Very small sensors are available which do not have the waterproof housing. These smaller sensors can be used for N, HO, etc. Contact RR Concepts for these sensors.

#### WARRANTY

Your StationMaster is warranted, and guaranteed operational for 1 year. It will be repaired or replaced at no charge within that time period. Contact <http://www.RR-Concepts.com> for additional information.